

March 4, 2001
1st - 6th Grades

2 Kings 8:16 – 13:25
2KG02

2 Kings



Baal Worship Destroyed

Materials I Need:



Legend:



-  = Option 1, Appropriate for 1st – 2nd Grade
 = Option 2, Appropriate for 3rd – 6th Grade



Memory Verse:

“Now I know that there is no God in all the world except in Israel.” 2 Kings 5:15b

Hook:

Total Destruction (Activity/Demonstration). ,  To illustrate the concept of total destruction, bring in several items to demonstrate. Use a potato with a bad spot or a piece of fruit with the beginnings of spoilage, and cut these bad spots out as you talk about how they will spread and ruin the entire fruit or vegetable if you don't. Ask the students to draw sad faces on the whiteboard while you draw happy ones. Once the entire board is full then stand back and take a look. Tell them that this morning they will hear what God did to the Baal worshipers in Israel to demonstrate His hatred and intolerance for sin. Take the eraser and wipe away every sad face on the entire whiteboard. Another illustration might be to use Play-Doh to construct as many small (3" high x 1" diameter) idols as you can. Try to fill the table. Explain that God pours out His wrath on those who worship false gods and idols. Now smash every idol as quickly as you can. Tell the students that God hates sin and will punish it severely. Think of some other items to show them, and allow them to totally eradicate or wipe out something.

Don't Repeat Your Mistakes (Discussion). ,  Talk about times when the students have made mistakes or wrong choices. Think of some ideas prior to class so that you can lead a discussion. Share some of your own shortcomings. What did you learn from those mistakes, and how do you keep from repeating them again? This morning the students will learn how God used the book of 2 Kings to remind His people of their past mistakes in worshiping the god Baal. We will hear what God finally did to end Baal worship among His people. It was swift and severe. He wanted people to learn from their past mistakes and remember the consequences of their sins.

Don't Do That Again (Game). ,  God did not want His people worshiping false idols again. Even though they had been taught before, they forgot. Play a game like Simon Says, but call it "Don't Do That Again." Select a couple of motions that you do not want the students to do, such as pat their heads, hop on one foot, or turn around in a circle. Tell them that, these motions are mistakes. If they do these motions during the game, they will be told "Don't Do That Again." Begin the game as you normally would play Simon Says. As you play, ask the students to do one of the actions that you had previously told them not to do. If you catch any students doing what is forbidden, stop the game and have the rest of the students tell them in unison... "Don't Do That Again." Continue the play. If any students repeat the forbidden action three times, they are out of the game. Let the students know that making mistakes in a game is not a sin. However, when we do sin, God is not pleased and wants us to repent and not repeat that sin again. God loves us and is patient with us, but because He is holy, He is justified in punishing sin. In today's Bible Adventure, the students will see how God's patience ran out and how swift He wiped out the sin of idol worship among His people.

 **Kings Mix-Up (Game).** 🧑🏽, 🦋 Before the students arrive, have chairs set up in a circle or have them sit in a circle on the floor. Go around the circle and give each student a name (use names from the story such as: Joash, Jehu, Ahab, Jezebel). You should have three to four students with the same name (if you need more names for a larger group, you could also use Elijah and Elisha). To begin the game, explain to the students that any time their name is called, they must switch places with someone with the same name. Begin very simply by calling one name at a time. As the game progresses, call more names or say, “Kings Mix-Up.” Everybody must switch, then the game continues until the students or teachers are thoroughly confused!

 **Blast the Baals (Beanbag Toss).** 🧑🏽, 🦋 Bring in a variety of objects that might be considered something that would be idolized by a child. These may be items that they may not consider idols: video games, CDs, dolls, toy trucks, stuffed animals, etc. They need to be items that can be stood up so that the students can knock them over with beanbags. Line up the idols on a table or on the floor across the room from the students. All students get a turn to knock over all of the idols. They may keep throwing until all of them are knocked over. Discuss with the students that, if those things meant more to them than the Lord, it would be considered an idol.

 **Chariots Are a Weapon (Discussion).** 🧑🏽, 🦋 Show the students the picture of the chariot on **2KG02.GF1**. Discuss how, just like today’s tank, it was an extremely devastating weapon of war for the time. Bring army men for the students to play with. Talk about the different types of weapons that were used by armies throughout history. Have as many different types of pictures of military items as you can find.

 **Draw Your Own Idol (Activity).** 🧑🏽, 🦋 As the students come into class, ask them to create and draw their own idol on a standing chalkboard using colored chalk. Encourage them to fill the empty space with their drawings while allowing every student the chance to draw an idol before sitting down. Beforehand, prepare the chalkboard with a few examples of your own creative drawings so that the students will quickly understand that you are intending a crazy-looking, fun drawing. After everyone has drawn his or her idol and sat down, discuss the abundant idolatry of God’s people during this time. (The chalkboard’s function is to communicate content to an audience. As the teacher, explain that you want to use the chalkboard for this very same reason, for teaching the students during BOOK time.) Ask the students what needs to be done to this chalkboard in order for it to accomplish its purpose today. After they answer, “clean the board,” in some manner or another, introduce the word “purge” and its meaning. To illustrate this purging, pull out your fully-loaded Super Soak’em and “flush out” the idols from the chalkboard. Wipe off the board with a towel while explaining that God’s purpose for His people is to communicate God’s Holiness (the content of Glory) to a much wider audience - the world. Proceed to use the board for teaching today’s Bible story where God purges His people of their idolatry so that they can again achieve their purpose of giving glory to God.

 **Baal Piñata (Activity).** 🧑🏽, 🦋 Take a large clothing gift box and fashion a shape something like a cloud or storm. Turn the box on edge. Tape the bottom securely. Cut the top with heavy-duty scissors to make the cloud shape. Put several handfuls of candy into the box. Staple the top edge securely and make a hole in the middle of the top for the string. Cover it with butcher paper and decorate it. Before class, tie the piñata securely to the ceiling. Explain to the students that Baal was the storm God who supposedly brought fertile rains. Blindfold one student at a time and give him or her three tries. Tell the students that in today’s lesson they will look at kings who destroyed idols to Baal.

 **What Is God’s Wrath? (Discussion).** 🧑🏽, 🦋 Ask the students the following questions: What does the word “wrath” mean? Is it possible for God to be angry with someone? What might cause this anger? How is God’s anger different from your anger when you get mad at someone for doing something you don’t like? Tell the students that in today’s Bible lesson, they’re going to see God’s anger towards His own rebellious people, the Israelites. Because God hates sin, He punished His people for their failure to obey Him, and they felt His wrath in a severe way!



Book:

Presentation Ideas -



Jehu Drives His Chariot Wildly and Furiously (Illustration/Coloring Page). 🦋, 🦋 2 Kings 9:20, 2KG02.GF2.



King Joram Is Shot with an Arrow (Illustration/Coloring Page). 🦋, 🦋 2 Kings 9:24, 2KG02.GF3.



The Worshipers of Baal Gather Inside the Temple of Baal (Illustration/Coloring Page). 🦋, 🦋 2 Kings 10:18-24, 2KG02.GF4.



The Temple of Baal Is Destroyed (Illustration/Coloring Page). 🦋, 🦋 2 Kings 10:25-27, 2KG02.GF5.



Johoiada Pronounces Young Joash as King Over Judah (Illustration/Coloring Page). 🦋, 🦋 2 Kings 11:9-12, 2KG02.GF6.



Dirty Laundry (Object Lesson). 🦋, 🦋 Prepare some clothing (perhaps second-hand dress clothes sized XXXL) with a heavy dose of mud or other stain that can be washed out with mere water and mild dish soap. Slip out of the classroom during the HOOK time to put these overly-stained garments on over your normal clothes. Alternatively, you may wish to be a fictional character who arrives at the classroom door only after a long introduction by a fellow teacher who anxiously stalls for your belated arrival. Perhaps Alaska's favorite "Sourdough Sam" will be a suitable storyteller. Moreover, add to the costume by wearing the old-style long red underwear with the button-away rear under the stained outer clothing. After stumbling into the classroom ashamedly, explain how you intended to wear you very best for this speaking engagement but tragedy struck while en route. Continue with glee when you discover that one of the props for today's lesson is an old-time washing tub with washboard and wringer. Proceed to wash these outer garments while telling the Bible story. Stop the story a few times to compare God's purging of His people from offensive idols with your purging your garments from offensive stains.

Note to teachers: In this lesson it may be difficult for the students to keep track of which kings are in Israel and which ones are in Judah. Pick one color for Judah and one color for Israel. You may either color the pictures or put the pictures on a backing so that the students can make a distinction.

Bible Adventure for K – 2nd Grades –

The books of 1 and 2 Kings were written as a history lesson for the people of Israel who were suffering as captives in the land of Babylon. God wanted them to know what had happened that caused them to live as prisoners in a foreign land. By examining Israel's past, hopefully the people would see the terrible mistakes of their ancestors and return to the true and living God of Israel.

The main sin that Israel had committed was turning their back on God and choosing to worship idols instead. The worship of the false god Baal was established in the northern kingdom of Israel when wicked King Ahab married his even more wicked wife, Jezebel. Then Ahab's grandson, King Ahaziah of Judah, thought it would be a great idea if Baal was worshiped in the southern kingdom, too. Baal was being worshiped everywhere, and God had had enough!

The Lord told the prophet Elisha to send one of his younger prophets to a man named Jehu. At this time Joram, the son of Ahab, was the king of Israel. Jehu was a commander in his army. The young prophet was to quietly anoint Jehu as the next king of Israel in place of Joram, who was wicked like his father. God wanted Jehu to completely wipe out Ahab's family (which included King Ahaziah of Judah and King Joram of Israel.) By doing this, God would end Baal worship in the land. Jehu was to move quickly before Joram got the news that he was about to be killed.

Jehu went to the city where both King Ahaziah and King Joram were. When Jehu approached the city, both kings drove out in their chariots to meet him. Joram asked if he came in peace and Jehu answered, "How can there be peace as long as all the idolatry and witchcraft of your mother abound?" (Remember,

Jezebel was the wife of Ahab who introduced Baal worship to the land.) When Joram realized what Jehu was saying, he fled and warned Ahaziah of Jehu's plans to destroy them. Jehu took out his bow and shot an arrow through Joram and killed him. When Ahaziah tried to escape, Jehu's soldiers shot him with an arrow, too.

Now it was time to take the life of wicked Jezebel herself. She ended up dying by being tossed out her window by her own court officials! If that wasn't enough, she was trampled over by Jehu's chariots and horses. Jezebel died a disgraceful, horrible death that was fitting for a woman who hated God! Next on Jehu's list were all of Ahab's sons and grandsons, a total of 70 men. Just as Elisha had prophesied, it came to pass that the entire family of Ahab was wiped out.

Not only did Jehu destroy the entire family of Ahab, he also destroyed any remaining worshipers of Baal. He gathered them all together at the temple of Baal. He then handed them different-colored robes to separate them from the worshipers of the Lord. Outside the entrance he stationed 80 of his soldiers to keep any of the Baal worshipers from escaping. On Jehu's signal, the soldiers rushed in and killed all those who worshiped Baal.

God used Jehu to wipe out Baal worship from the northern kingdom of Israel but he used another king named Joash to wipe it out in the southern kingdom of Judah. Joash was only a boy when he became king but he was part of God's plan to put a stop to His people's wicked idolatry.

In these chapters of 2 Kings, we can see the anger of God being poured out on the worshipers of Baal. There comes a point in God's plan when enough is enough! The people had disobeyed long enough and now it was time for them to receive their punishment. This whole episode was a warning to the captives in Babylon that God hates sin and will punish it severely. God **never** does wrong when he punishes sin. Because He is perfect and holy, God will never let sin go. Think of your own life. Jesus died on the cross and took the punishment for your sin. Give your life over to Him and receive His gift of forgiveness. Then you will not have to be like the Baal worshipers, waiting for God's wrath to be poured out on your head!

Bible Adventure for 3^d – 6th Grades –

We've learned that the book of 2 Kings was written to the Jewish exiles in Babylon who were there because of Israel's past sins. For over 300 years, the once-loyal nation of Israel turned its back on God. And why did they do this? They did it in to order worship a false god by the name of Baal, the god of the pagan nations of Canaan. The people believed that Baal blessed the land with rain and caused things to grow. Worship centers were set up throughout the ten northern tribes so that the Israelites could sacrifice to this false god.

The worship of Baal began among the ten northern tribes during the reign of King Ahab when he married Jezebel. Obviously, the Lord was very displeased with this disobedience and abandonment of Himself as the true and living God of the universe. Therefore, for the exiles, this was not only a history lesson on how they got where they were, but also a spiritual lesson for them to apply to their own lives. By reviewing Israel's past, the exiles were able to see the great mistakes of those who had gone before them, and hopefully, would seek the Lord instead.

The ten northern tribes of Israel had been worshiping Baal for a long time. Nineteen kings, one after the other, failed to walk with the Lord and continued in the ways of Baal worship. It wasn't until King Ahaziah that Judah, the southern kingdom, also turned to Baal. You see, Ahaziah was the son of Athaliah, who was the daughter of Ahab. Through the influence of one family, Baal was now being worshiped throughout Israel and Judah. The Lord had had enough!

The Lord told Elisha to send one of his younger prophets to Jehu. At the time, Joram, the wicked son of Ahab, was Israel's king. When the prophet found Jehu, he secretly anointed him as the next king of Israel. Jehu had been chosen by God to completely wipe out Ahab's family, and thus get rid of the worship of Baal in the land. He was to go quickly, before word could leak out to Joram about his plans.

Jehu went to Jezreel where king Joram of Israel and king Ahaziah of Judah were. When Jehu approached the city, both kings drove out in their chariots to meet him. Joram asked if he came in peace, and Jehu responded, "How can there be peace as long as all the idolatry and witchcraft of your mother Jezebel abounds?" Joram realized what Jehu was saying, that he was taking a stand against his and his mother's reign of evil. Joram turned his chariot around and fled, warning Ahaziah of the danger. Jehu

took out his bow and shot an arrow through Joram and killed him. When Ahaziah tried to escape, Jehu's soldiers shot him with an arrow and he died also.

Now it was time to deal with Jezebel, the wife of Ahab, the wicked woman who brought the worship of Baal into Israel. As Jehu watched, Jezebel died as the result of being thrown out her window by her own court officials. She was then trampled by Jehu's chariots and horses. Jezebel died a disgraceful, horrible death that was fitting for a woman who hated God!

Finally, all of Ahab's sons and grandsons, a total of 70 men, were killed, along with all of Ahab's officials. Just as Elijah had prophesied (1 Kings 21:17-24), it came to pass that the entire house of Ahab was wiped out.

Not only did Jehu destroy the entire family of Ahab, he also destroyed any remaining worshipers of Baal. He did this by declaring that his loyalty to Baal would be even greater than Ahab's. He called for all the worshipers of Baal in Israel to gather together at the temple of Baal. When they arrived he handed them separate robes to distinguish them from the worshipers of the Lord. Outside the entrance, he stationed 80 soldiers to keep any of the Baal worshipers from escaping. When he gave the men his signal, they entered the temple and killed all those who worshiped Baal.

God used Jehu to remove Baal worship from Israel; but unfortunately, Jehu worshiped the two golden calves that were set up by the northern kingdom's first king, Jeroboam (1 Kings 12:28-33). It seems that Jehu's reasons for getting rid of Baal were more political than spiritual. The Bible says of him, "Yet Jehu was not careful to keep the law of the LORD, the God of Israel, with all his heart." As a result of his idolatry, the Lord punished Israel by allowing Syria to conquer its land east of the Jordan River.

When Jehu killed Ahaziah, his mother Athaliah, who wanted to take the throne for herself, killed all her grandchildren so that none of them could become king. By doing so, she came close to putting an end to the Davidic line. In God's sovereignty, one of Ahaziah's sisters (Jehosheba) took Joash, a remaining son of Ahaziah, and hid him from Athaliah for six years. When Joash was seven, Jehoiada, the high priest, brought him before the people and pronounced him the king of Judah. First, he had to secure the loyalty of the royal guards to protect Joash. When Athaliah tried to stop them from doing this, Jehoiada had her killed.

With Athaliah out of the picture, Jehoiada made a covenant between the Lord and the king and the people. The people then went throughout the land and tore down the altars of Baal. Just as the Lord used Jehu in Israel to rid the land of idolatry, He used Jehoiada to do away with it in Judah. Even though Joash was very young when he took the throne, Jehoiada, the high priest, who desired to see the Lord worshiped once again in Judah, guided him.

Joash did what was right in the sight of the Lord. He also came up with a plan to raise money to help repair damages to the temple and to replace the items used for the sacrifices. But when Jehoiada, the high priest, died, Joash fell into sin and the Lord stripped the throne away from him.

These events from the book of 2 Kings may seem extreme, even shocking to us. God's wrath was poured out on the worshipers of Baal and there was no escape. But keep in mind that God allowed His people to continue on in rebellion to Him for about 300 years! The Bible tells us that God is slow to anger, but He must and will eventually punish sin because He is holy. There comes a time in God's plan when enough is enough. His people had disobeyed long enough, and now they would receive the punishment they deserved. The Jewish exiles in Babylon would read about the punishment and be warned that God hates sin and will punish it severely. Those who totally abandon Him and worship false evil gods will not escape His anger.

God gave warning after warning to His people that they were to have no other god but Him. He was and is fully just and right to punish His people when they shake their fists in His face and say, "I'll do what I want to do." When you think about the kind of rebellion shown to God every single day, don't you think it's amazing that He allows the world to continue to exist? We know, though, that there will come a time when He says, "Enough is enough." Don't wait for God's wrath to be poured out upon your head! Obey today and make sure your heart is right before Him.

Aim Questions:

1. Which king of the northern kingdom brought Baal worship into Israel? *Ahab.*
2. Whom did the Lord appoint to destroy Baal worship in Israel? *Jehu.*
3. What did God command Jehu to do to the entire house of Ahab? *Destroy them all.*
4. What wicked woman did Jehu also kill? *Jezebel.*
5. Which king of the southern kingdom did God protect from Athaliah? *Joash (Jehoash).*
6. What did Joash do to the altars of Baal? *He had them all torn down and destroyed.*
7. What can we learn about the character of God in this passage? *He is a holy God who will punish sin.*



Look:



Baal Pop-up (Craft). 🦋, 🦋 Copy **2KG02.GF7 Pgs. 1-3** onto white paper for each student. Have the students fold **2KG02.GF7 Pgs. 1 & 2** into cards by folding in half from top to bottom and then again in half from left to right side. Have them glue the two cards together with the last page of the first card to the first page of the last card. Next, have them cut out the half-circle shapes on **2KG02.GF7 Pg. 3** and fold on dotted lines. Then, have them fold the tabs up toward the top and fold on the centerline, keeping the lines visible. Have the students cut out the images of Baal and the ark and decorate the pages and images as desired.

To assemble: Take one half-circle and place a piece of tape on each tab (printed side). Attach one tab to the “holiness” card in the middle. Fold piece into the card and attach other tab while in the folded position. (When the card is opened the half-circle piece will stand up.) Do the same with the “lightning” card. Fold “Baal” and the “ark” in half so that the image is visible and attach each to its respective half-circle pop-up.



Bowling for Baals (Game). 🦋, 🦋 During this activity, have each of the students take turns in knocking over the idols. Line up the students across the room from the idols that are set up like in a bowling alley. They get two rolls of the ball (one for Joash and one for Jehu). Prior to rolling the ball they are to say, “**I’m Joash, and I am bowling over the Baals for God.**” Obviously during the second roll they would say, “**I’m Jehu, and I am bowling over the Baals for God.**” Prior to class, make up (6-10) idols, in a variety of shapes, to be used as “Baal” pins. These can be made out of either milk cartons, two-liter soda bottles, dolls, plastic bowling pins, or anything else that you have that would be the appropriate size. Bring a ball of some type that is heavy enough to knock over the Baals. Decorate the pins to look like idols, i.e., gold paints or foil, with ugly faces, etc. (In the event that there is snow outside, you may wish to use snowmen and real bowling balls.) You can turn this into a small tournament, if time permits.



How Does It All Add Up? (Worksheet/Craft/Discussion). 🦋, 🦋 Write two simple (grade appropriate) math problems on the top half of the whiteboard. Call on a student to solve each one. Ask the other students if the answer is correct. If an incorrect answer is given, help the student come to the correct answer before filling in the solution on the board. Could there be any other answer that would still make the sentence true? No, there could not. Tell them that they will be able to solve the “spiritual math” problems you are about to hand out to them by remembering what they learned of God’s truth in today’s Bible Adventure. Give each student **2KG02.GF8 Pgs.1 & 2**. Ask them to cut out the words and place them in the correct boxes. While they think about their answers and arrange the words to their satisfaction, use the lower half of the whiteboard, making a larger version of the “spiritual math” problems the students have been given. Put the word SIN in the first box and then call on a student to fill in the solution. Call on two more students to complete the second problem correctly. Is there any other answer/solution to this math sentence? No. Explain that this is truth. It never changes. It always will be true. Read the sentences at the bottom of the worksheet. Answer any questions the students have about God’s holiness, our sinfulness, and our need of forgiveness to be right with Him.

- Baal Balloons (Activity).** 🦋, 🦋 Blow up a number of balloons with several copies of the Passage Review questions cut apart and put inside. Make sure to blow up enough balloons for each student in the class. Give each a turn in coming to the front of the class and popping the balloon any way he or she can. Once the balloon is popped, have the student answer the review question inside. The questions will be repeated often so that the students really get the main ideas.
 - Spilled Vowels (Memory Verse Activity).** 🦋, 🦋 Have the students place the vowels in the appropriate spaces to discover what the memory verse is for today, **2KG02.GF9**.
 - Aim Questions (Worksheet).** 🦋 Have the students answer the Aim Questions about today's Bible Adventure, **2KG02.GF10**.
 - Passage Review Questions (Worksheet).** 🦋, 🦋 This booklet contains many questions from the Scripture passage covered in today's lesson. The students may work on them in class and complete them during the week at home, **2KG02.GF11**.
 - 2 Kings 5:15b (Memory Verse Song).** 🦋 Words and music for today's memory verse are available upon request from Children's Ministry.
-



Took:

- The Joash and Jehu Chariot Race (Game).** 🦋 Items needed: Two sturdy wheelbarrows (these can be decorated to look like chariots), about 20-24 idols (2-liter bottles or brown paper bags with faces drawn on them, or you may wish to use paper plates on a stake), and two brooms. It is also better for those chosen to be the horses to pull the wheelbarrows instead of pushing. (Whoever heard of a horse pushing a chariot?) The object of the race is to be the first team (either the Jehu team or the Joash team) to knock over all the idols, using the broom, without falling off of the chariot. This activity is best done outside. If weather does not permit outside activity, use scooters, tarps, or sheets of heavy plastic. Throughout the church property place the idols, half for each team in their designated areas. Each team starts with three team members; one as Joash or Jehu and the other two as horses. They are to race to each idol and destroy it. They then return to the starting line and the next person jumps into the chariot and destroys the next idol. This continues until all idols are destroyed. (If at any time during the race the charioteer falls out of the chariot, he/she is to return to the starting line prior to destroying the designated idol.)
- God's Wrath Revealed (Discussion).** 🦋, 🦋 Have you ever received consequences for your actions? Have you ever been punished for the sins that you have committed? Explain that we all have sinned and fallen short of the glory of God (Romans 3:23). Each time that we sin we are sinning against God, and when we do we deserve to be punished. We do not know when God will choose to punish us because He chooses the timing. Lets take a look at some of the times when God's wrath was seen in the Bible. Share with the students some examples in the Bible where God has used His wrath. Choose from the examples or choose one of your own: Korah rebellion (Numbers 16); Ananias and Saphira (Acts 5:1-11); Sodom and Gomorrah (Genesis 18-19).
- Compassion for the Lost (Discussion/Guest Speaker).** 🦋, 🦋 Knowing that God will ultimately pour out His wrath upon those who worship other gods, our compassion for the lost should be a natural ending to the lesson from this morning. You might choose to discuss other religions, false gods, idols in our lives, or focus generally on those without Christ. Ask the students to pray for those people all over the world to come to Christ and worship the only true God. Invite someone who has served on the mission field to come to your class and talk about other religions they encountered and how they witnessed to those around them.



God Is Holy and Punishes Sin (*Discussion/Craft*). 🦋, 🦋 Each student will need:

- craft instruction sheet from **2KG02.GF12 Pg. 1**
- cross figure from **2KG02.GF12 Pg. 2** copied onto colored cardstock
- tissue paper
- scissors
- glue

Discuss with the students how all sin deserves God's wrath. God is perfect and holy. There cannot be any sin in His presence. Christ was sacrificed on our behalf to bear our sins—past, present, and future. Explain that, if we have surrendered our lives to Christ, we are forgiven and can have a restored relationship with God the Father. Do your students understand the seriousness of their sin, and the forgiveness that they can receive through Christ? As you talk about this, have the students construct a stained glass cross as diagrammed on **2KG02.GF12 Pg. 1**. They can either use these as bookmarks or share them with a friend who doesn't know Christ.

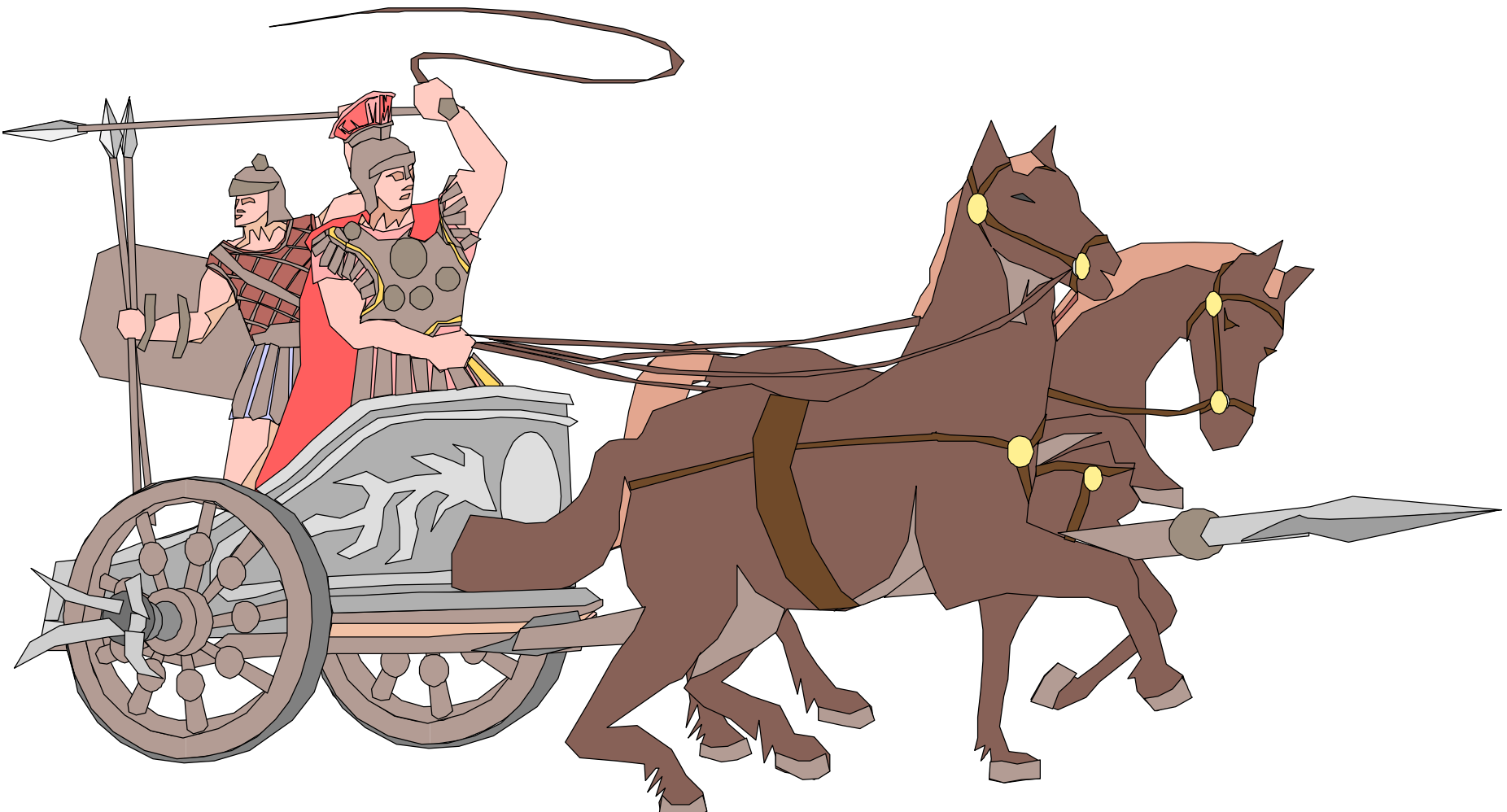

Jehu Drives His Chariot Wildly and Furiously

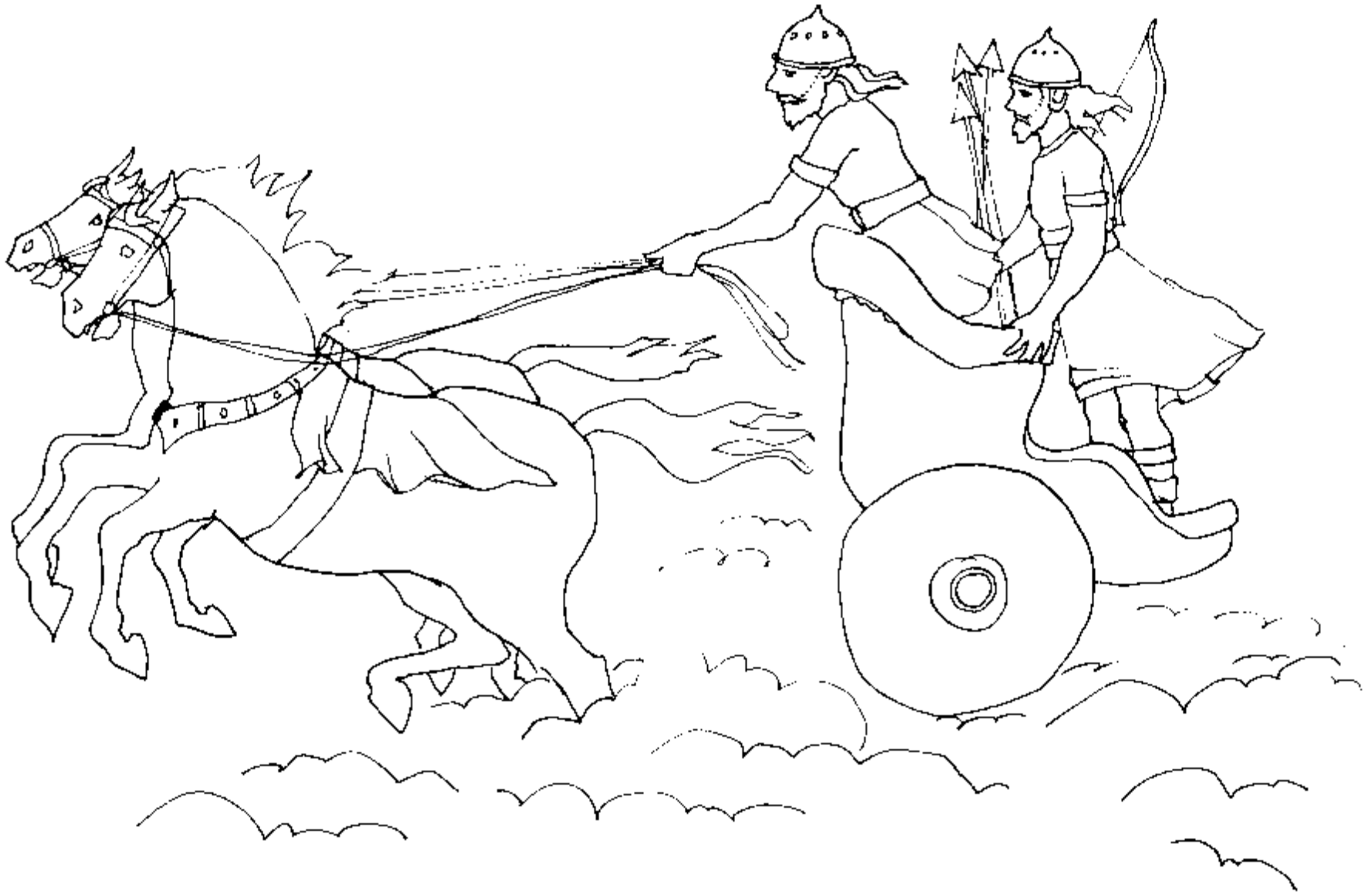

King Joram Is Shot with an Arrow

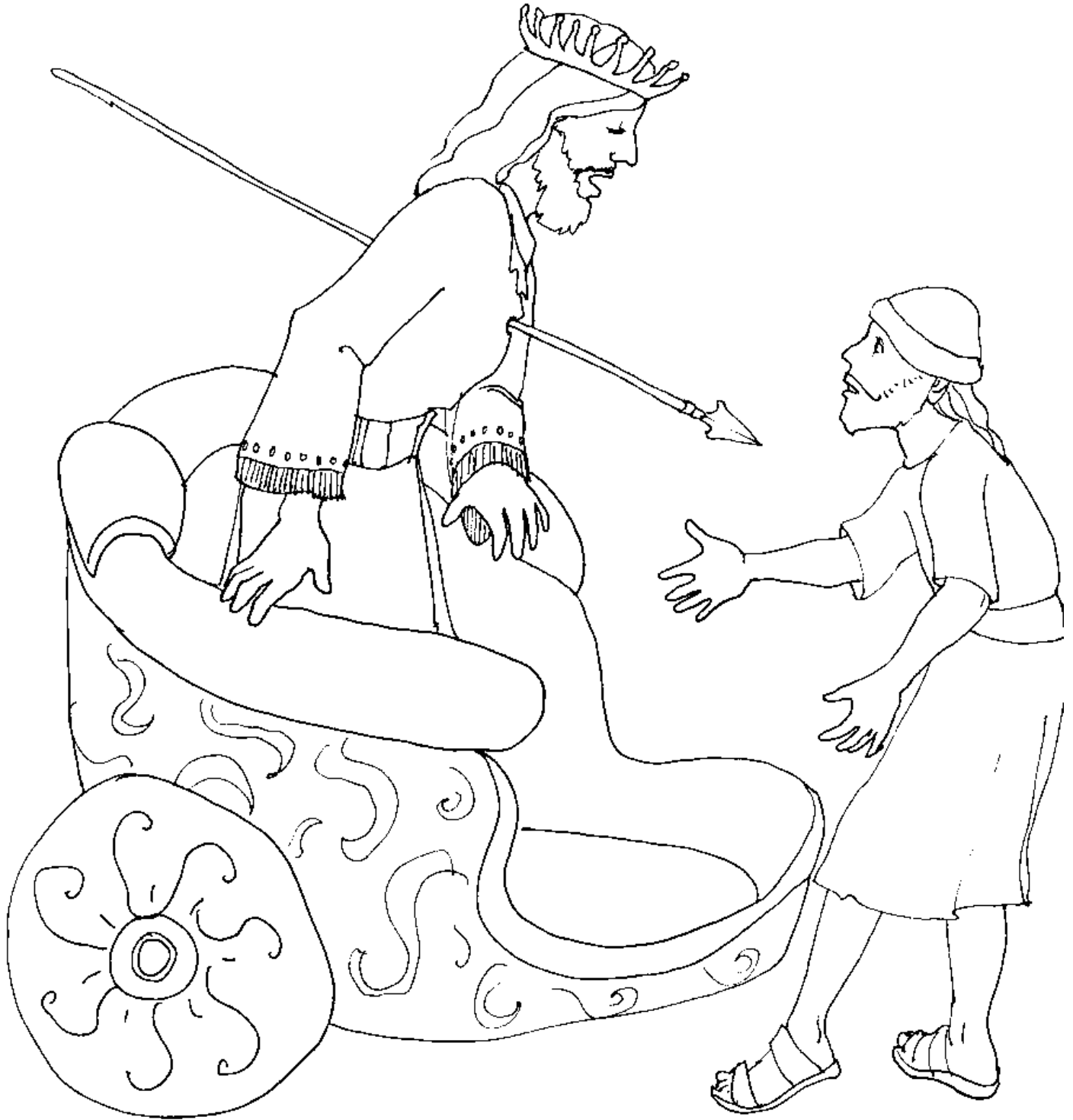

The Worshipers of Baal Gather Inside the Temple of Baal

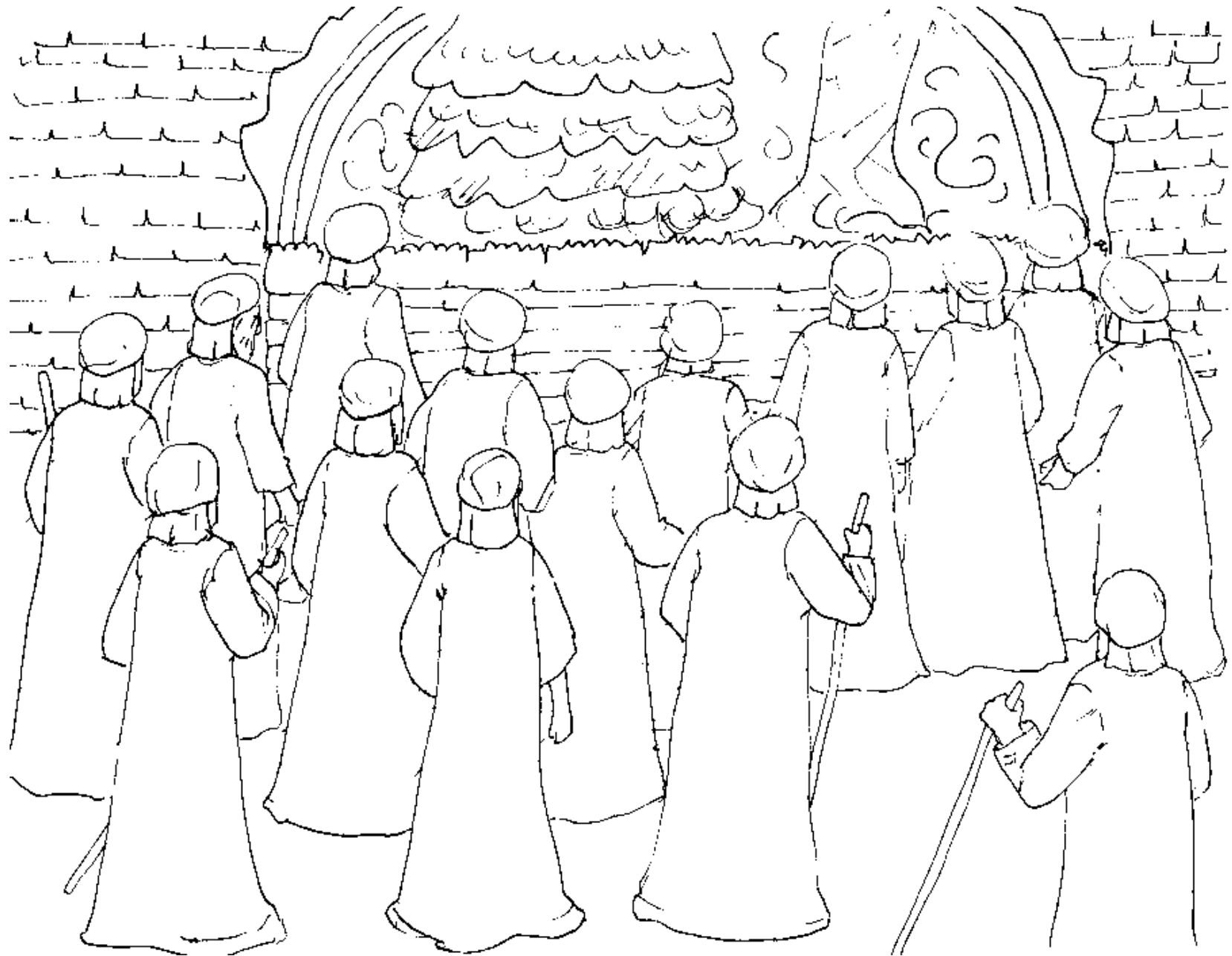

The Temple of Baal Is Destroyed



Johoiada Pronounces Young Joash as King Over Judah



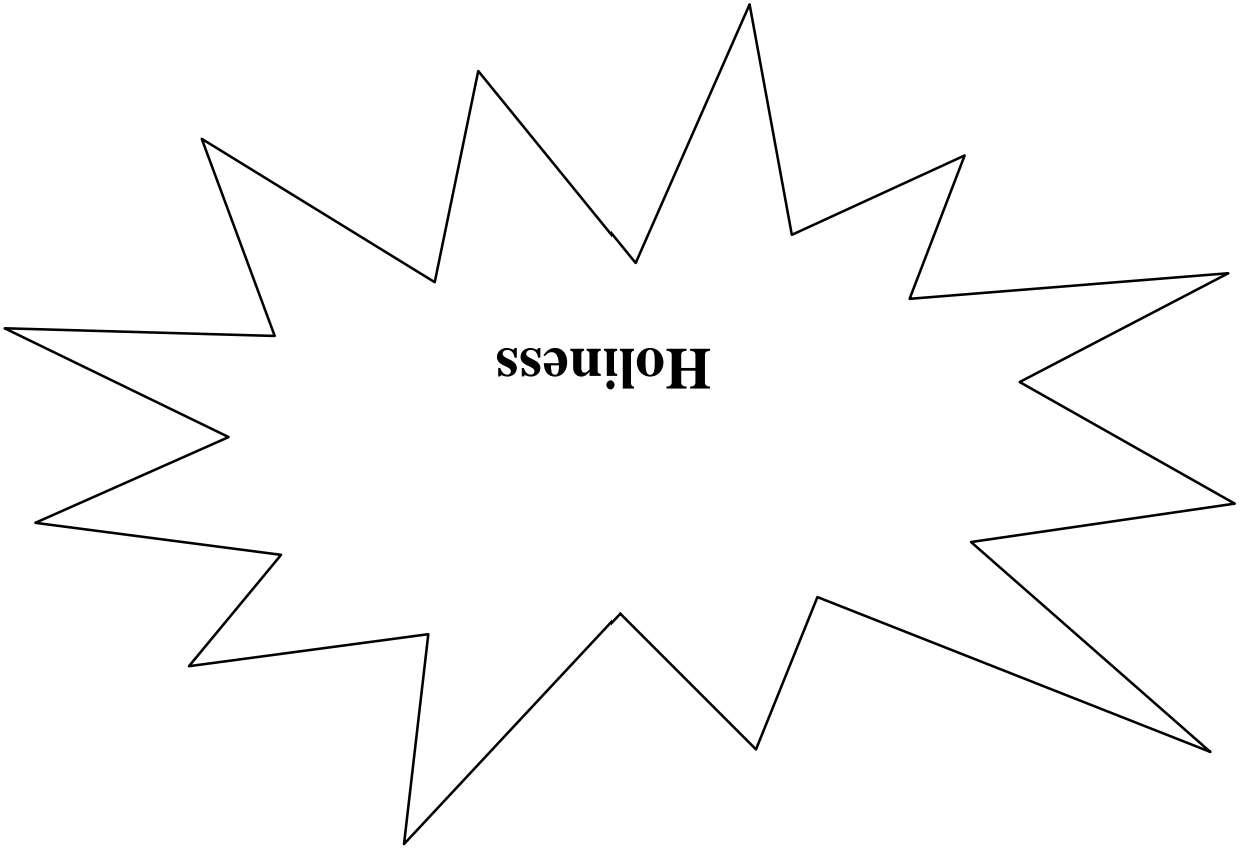

Glue this back page to the front page of the second booklet.

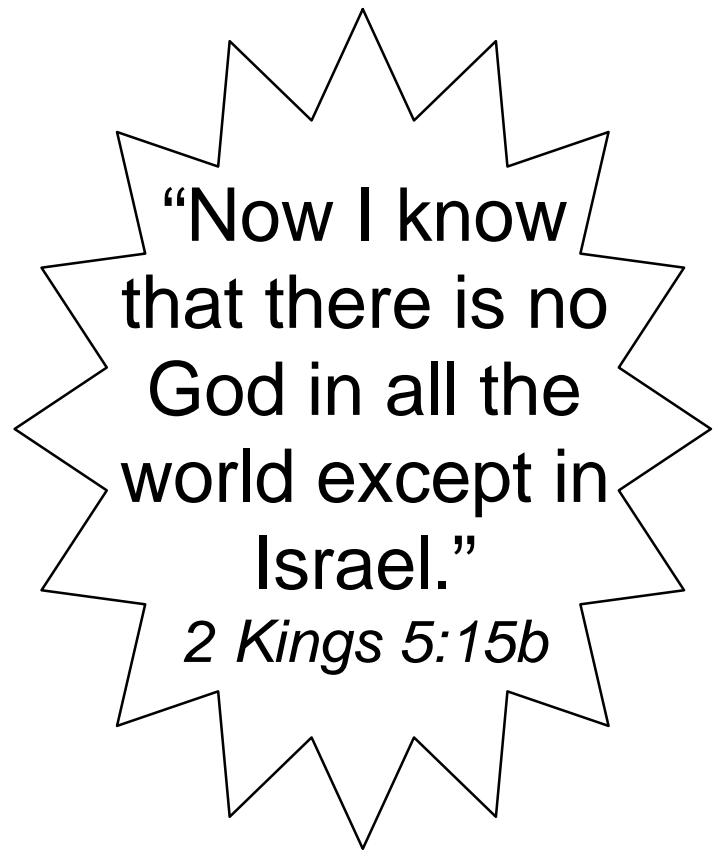

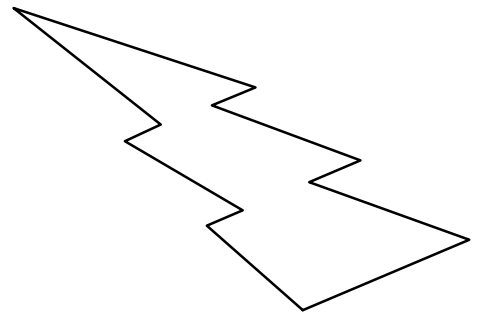
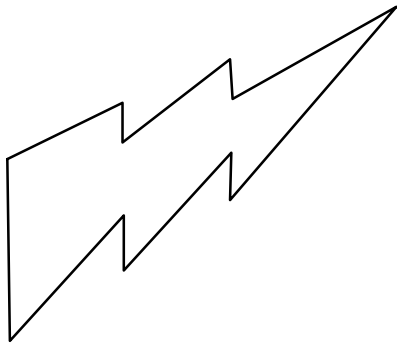
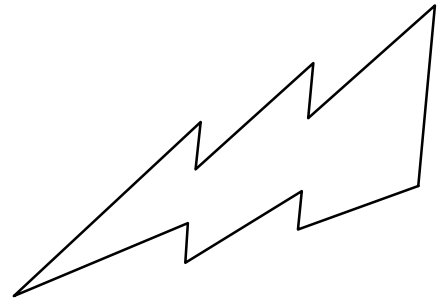
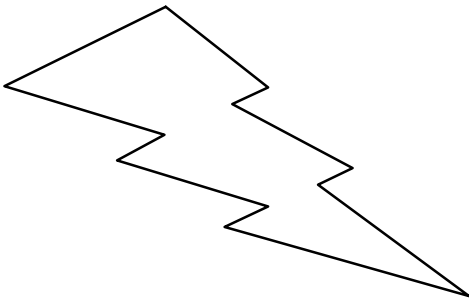

Glue this front page to the
back page of the first
booklet.

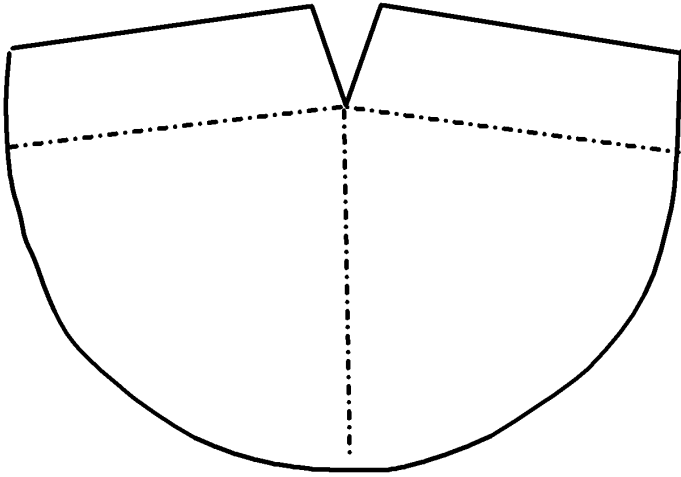

BAAL

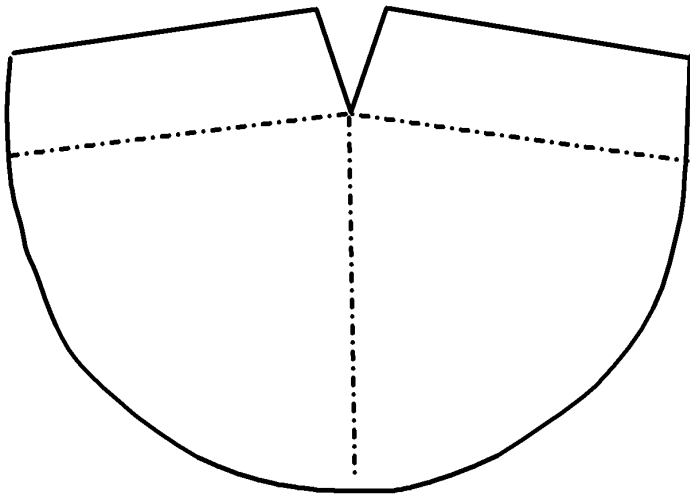

ARK

HOW DOES IT ALL ADD UP?

Glue each of the four word boxes onto the right box below to complete the "Spiritual Math" problem correctly.

The image shows two identical rows. Each row starts with a stick figure (a circle for a head, a horizontal line for arms, a vertical line for a torso, and two diagonal lines for legs). To the right of the stick figure is a large plus sign (+). To the right of the plus sign is a large, empty square box. To the right of this box is a large equals sign (=). To the right of the equals sign is another large, empty square box.

Because He is perfect and Holy, God will never let sin go.
Jesus died on the cross and took the punishment for your sin upon Himself.
Give your life over to Jesus and receive His gift of forgiveness.
Don't be like the Baal worshipers waiting for God's wrath to be poured out on your head!

*God's
Wrath*

*God's
Forgiveness*

SIN

JESUS

SIN

JESUS

*God's
Forgiveness*

*God's
Wrath*

SPILED VOWELS

All the vowels have spilled out of the memory verse below. They have been rounded up, but they need to be put back in the right place. Can you find out what the words say?
Hint: Cross out the vowels as you use them.

2 K__NGS 5:15b

"N__W __ KN__W TH__T
TH__R__ __S N__ G__D
__N __LL TH__ W__RLD
__XC__PT __N __SR__ __L."

<u>A'S</u>	<u>E'S</u>	<u>I'S</u>	<u>O'S</u>
A A A	E E E E E E	I I I I I I I	O O O O O

Aim Questions

Answer the following questions about today's Bible Adventure.

1. Which king of the northern kingdom brought Baal worship into Israel?
2. Who did the Lord appoint to destroy Baal worship in Israel?
3. What did God command Jehu to do to the entire house of Ahab?
4. What wicked woman did Jehu also kill?
5. Which king of the southern kingdom did God protect from Athaliah?
6. What did Joash do to the altars of Baal?
7. What can we learn about the character of God in this passage?

Turn to the one and only Holy God of the universe.

Make sure your heart is right before Him.

Ask Him to reveal to you any false gods that you have in your life.

Ask God for the desire and the strength to wipe them from your heart and replace them only with Himself.



"Now I know that there is no God in all the world except in Israel." 2 Kings 5:15b

Passage Review Questions

2 Kings 8:16 - 13:25

After Elijah was gone, how did Elisha know that God had given him the same power as Elijah? (2:14)

How did Elisha help the widow and her sons pay off their debt? (4:1-7)

How did Elisha bring the Shunammite woman's son back to life? (4:34)

According to 2 Kings 5:15b, who is the only true God? (5:15b)

Was the Lord willing to destroy Judah? (8:19)

Who was Joram's father? (8:25)

What did Elisha send one of his younger prophets to do? (9:1-3)

Who brought the worship of Baal and idolatry into Israel? (9:22)

What happened to King Joram of Israel and King Ahaziah of Judah at the city of Jezreel? (9:24-27)

What happened to Jezebel? (9:33)

What happened to all of wicked Ahab's sons? (10:6-7)

Did Jehu allow Baal worshipers to continue disobeying God by worshipping a false god? (10:25)

Did Jehu allow the places of worship of Baal to continue to exist in Israel? (10:25-28)

How did Jehu fail as a king of Israel? (10:31)

How did Athaliah secure her place as queen of Judah? (11:1)

Who was the only royal offspring to survive? (11:2)

How did Jehoiada, the high priest, make it safe to present the new king, Joash, to the people? (11:4-8)

What happened to Athaliah for her sinful life and disobedience to the Lord's commands? (11:16)

Did Joash finish well as king over Judah? (2 Chronicles 24:17-25)

God Is Holy and Punishes Sin

Cross craft

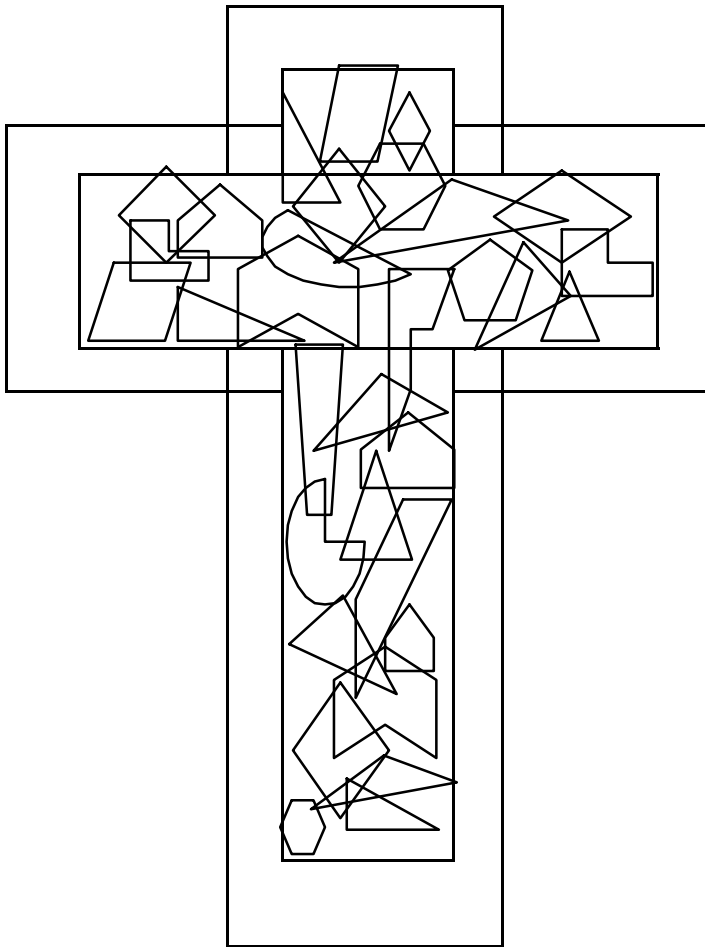

Stained glass appearance on the front.

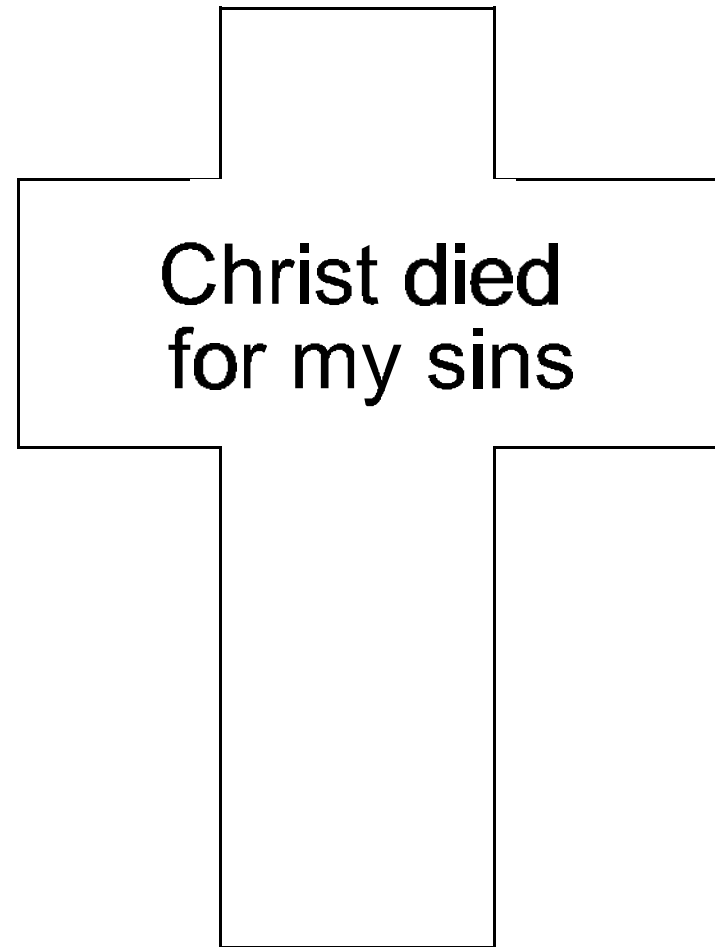

Gospel message on the back.

This page makes two crosses.

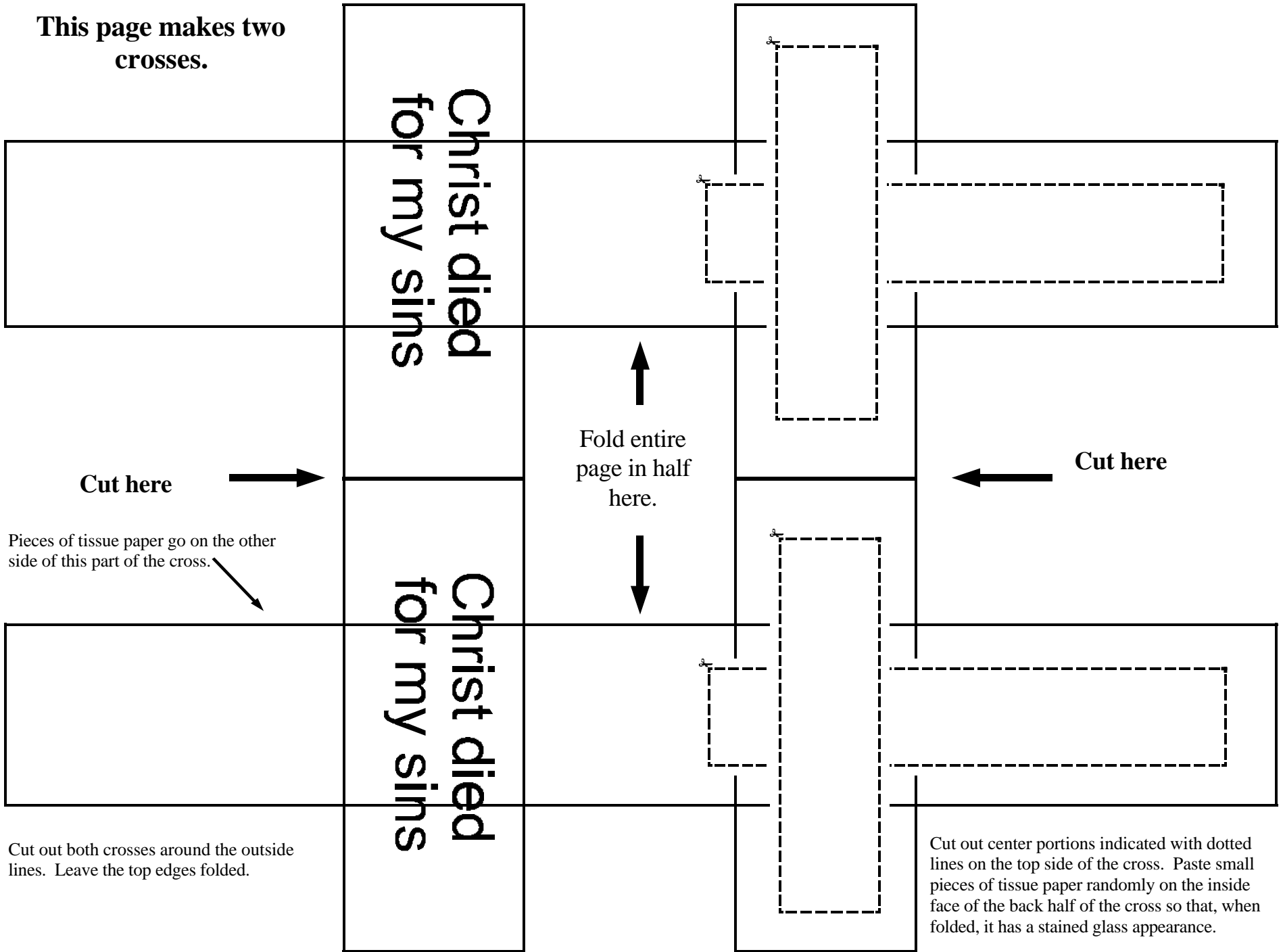

Cut out both crosses around the outside lines. Leave the top edges folded.

Cut out center portions indicated with dotted lines on the top side of the cross. Paste small pieces of tissue paper randomly on the inside face of the back half of the cross so that, when folded, it has a stained glass appearance.



Don't Do That Again

God did not want His people worshiping false idols again. Even though they had been taught before, they forgot. Play a game like Simon Says, but call it "Don't Do That Again." Select a couple of motions that you do not want the children to do, such as pat their heads, hop on one foot, or turn around in a circle. Tell them that these motions are mistakes. If they do these motions during the game, they will be told "Don't Do That Again." Begin the game as you normally would play Simon Says. As you play, ask your children to do one of the actions that you had previously told them not to do. If you catch any doing what is forbidden, stop the game and have everyone else tell them in unison..."Don't Do That Again." Continue to play. If any children repeat the forbidden action three times, they are out of the game. Let them know that making mistakes in a game is not a sin. However, when we do sin, God is not pleased and wants us to repent and not repeat that sin again. God loves us and is patient with us, but because He is holy, He is justified in punishing sin. In this week's passage, your family will see how God's patience ran out and how swift He wiped out the sin of idol worship among His people.

Watch Out for Idols in Your Home

Most of us don't struggle with worshiping statues and figurines of false gods. However, there are so many other things than can distract our children away from the Lord: TV, video games, toys, bad friendships, card collections, etc... Your job as a parent is to guard your child's heart. What do they spend most of their time thinking about and doing? What things do they think will make them happy? Balance is the key. Discuss with them how they can enjoy things they own and do but not at the expense of their relationship with the Lord.

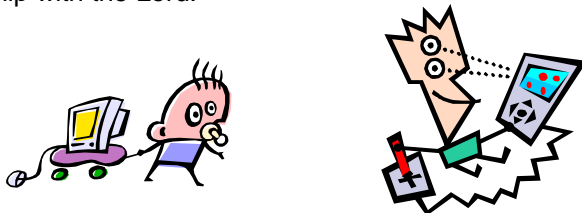

FAITH BIBLE CHURCH

03/04/2001

FAMILY FUN SHEET

This is what we learned today:

Passage ~ 2 Kings 8:13-13:25

Memory Verse ~ "Now I know that there is no God in all the world except in Israel."

2 Kings 5:15b

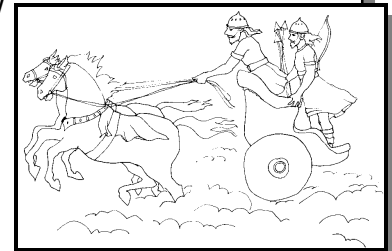

Application Points ~

- ◆ God is fully justified in punishing people for sin.
- ◆ Don't wait for God's wrath to be poured out upon your head!
- ◆ Obey today and make sure that your heart is right before Him.



Seek Ye First

by Karen Lafferty

Seek ye first the kingdom of God,
And His righteousness.
And all these things shall be added unto you,
Hallelu-hallelujah.

Ask and it shall be given unto you,
Seek and ye shall find.
Knock and the door shall be opened unto you,
Hallelu-hallelujah.

Man does not live by bread alone,
But by every word
That proceeds from the mouth of God,
Hallelu-hallelujah.

PASSAGE

- Daily Bible Reading:** There are many, many characters in these chapters. Select just a few kings for each day. Make the contrast between good kings and bad kings. How did God evaluate a king?

Day 1: Chapter 8

Day 2: Chapter 9, 10

Day 3: Chapter 11

Day 4: Chapter 12

Day 5: Chapter 13

- Family Bible Night: 2 Kings 9-10**

The Lord told Elisha to send one of his younger prophets to Jehu. At the time, Joram, the wicked son of Ahab, was the king. When the prophet found Jehu, he anointed him privately as the next king of Israel. Jehu had been commissioned by God to completely wipe out Ahab's family and, thus, eradicate the worship of Baal from the land. He was to go quickly, knowing that word could leak out to Joram that a coup was about to begin.

Jehu went to Jezreel where King Joram of Israel and King Ahaziah of Judah were. When Jehu approached the city, both kings drove out in their chariots to meet him. Joram asked if he came in peace, and Jehu responded, "How can there be peace as long as all the idolatry and witchcraft of your mother Jezebel abound?" When Joram realized what Jehu was saying, he turned his chariot around and fled to warn Ahaziah of the coup. Jehu took out his bow and shot an arrow through Joram and killed him. When Ahaziah tried to escape, Jehu's soldiers shot him with an arrow and he died.

Now it was time to take the life of Jezebel, the wife of Ahab and the wicked woman who brought the worship of Baal into Israel. She died as a result of being thrown out her window by her own court officials and trampled over by Jehu's chariots and horses. Jezebel died a disgraceful, horrible death that was fitting for a woman who hated God! Next on Jehu's list were all of Ahab's sons and grandsons, a total of 70 men. Each was killed, along with all of Ahab's officials. Just as Elijah had prophesied in 1 Kings 21:21, it came to pass that the entire house of Ahab was wiped out.

PERSONAL APPLICATION

Don't Mess with God's Holiness!

In these chapters, we find the wrath of God being poured out upon the worshipers of Baal. There comes a point in God's plan when enough is enough. The people had disobeyed long enough, and now it was time for them to receive their due punishment. God even used imperfect people to carry out His wrath ~ Jehu in Israel and Joash in Judah. This should have served as a stern warning to the exiles who were listening, that God hates sin and will punish it severely. The people had totally abandoned their God and worshiped a false, evil idol.

God is fully justified in punishing people for sin. We should be amazed that He shows mercy to anyone! God's holiness demands a penalty for disobedience, and sometimes He takes it out in a radical way, as He did here. Don't wait for God's wrath to be poured out upon your head! Obey today and make sure that your heart is right before Him.

PRAYER

Uncover Sinful Thoughts and Habits

Psalms 139:23,24 asks God to search our hearts and uncover any sinful ways.

Most children do not like to recognize their sin. Most adults don't, either. Don't let unconfessed sin linger in your hearts. Pray as a family that God would uncover sin in your lives and then give you the grace to deal with it. Don't be proud and fear what the rest of the family might think. Seek to be pure before the Lord. Be honest with each other and allow your children to tell you what they see in your life. It is eye-opening and humbling, but very beneficial.