

March 25, 2001

1<sup>st</sup> - 6<sup>th</sup> Grades

King Josiah and Judah's Downfall

2 Kings 22 - 25

2KG05

# 2 Kings



Materials I Need:

Legend:

 = Option 1, Appropriate for 1<sup>st</sup> – 2<sup>nd</sup> Grade



 = Option 2, Appropriate for 3<sup>rd</sup> – 6<sup>th</sup> Grade



Focus Verse:



Memory Verse:

“He held fast to the LORD and did not cease to follow Him; he kept the commands the LORD had given Moses.” 2 Kings 18:6

 Hook:

**The Book of the Law (Questions and Answers/Discussion).** ,  Spend a few minutes reviewing portions of the Old Testament that talk about the Word of God as it was first given to Moses and the Israelites. Show pictures of Moses with the stone tablets, the ark of the covenant, the tabernacle, and the priest reading the law from **2KG05.GF1**. Talk about how the Word of God was recorded in the Old Testament. Tell the students that this morning they will learn about the treasure we have in God's words to us through the Bible.

**Mystery Treasure Hunt (Activity).** ,  This morning the students will learn that God's Word, the Bible, is our life's treasure. It is God-breathed, inspired, and without error. As the students arrive, send them on a treasure hunt using the clues from **2KG05.GF2 Pg. 1**. Make multiple copies of these clues so that you will have enough for several groups. The instructions for the treasure hunt setup are on **2KG05.GF2 Pg. 2**. Students may work alone or in groups, but instruct them to keep the answers to themselves so that all of the students may work at their own pace. Once everyone has completed the hunt, you may ask them what the treasure was. Set the clues up in your classroom, or expand your hunt to include a larger area. The end result is finding the Bible, which is our treasure.

**Play Telephone (Activity).** ,  The objective of this activity is to demonstrate how we are apt to lose part of the translation in the verbal presentation, as opposed to the written translation. Set the students in a row and whisper something to the first student. Be sure that whatever you whisper is complex enough that when it reaches the other end, it will not be the same. The next student repeats to the next student what he or she thinks was heard, and so on. All is repeated in a whisper. The last student then shares with the group what was whispered to him or her. Compare this with what was actually whispered by the teacher. Now try the same thing, only this time give the first student a piece of paper with something written on it. Have each student read it and pass it to the next, and so on down the line. At the end, what is shared should be what the teacher started with. This demonstrates the effectiveness of the written word; there is much less room for error. Explain that that is why God has given us His Word, the Bible, in written form. We have it to read and not just to remember what our parents and teachers have told us. The Bible is special revelation because it is God's way of telling us about Himself. It's so wonderful to have His written instructions for us.

 **Lost and Found (Discussion).** 🦋, 🦋 Ask the students to name something important or special to them that they once lost. How did they feel? What did they do? Did they ever find it? How long was it lost? How did they feel when it was found? Ask them if they've ever found or discovered something that they weren't looking for, perhaps while on a walk, exploring somewhere, or even in an old scrapbook or trunk. What was it they found? Was it exciting? Was it surprising? What happened to it? Explain that in today's Bible Adventure, they will hear the true story of finding something important and special that had been lost for many years.

 **Surprise in the Rubble (Activity).** 🦋, 🦋 Have a corner of the room filled with a pile of miscellaneous things. This can be chairs, boxes, blankets, bins, cans, etc. After the students arrive, tell them that someone has left a huge mess from the night before and that before we can begin class this morning, we will need to clean it up. They may grumble a bit about having to clean up the mess, but hopefully once they begin cleaning and find the candy you have hidden in the rubble, they will want to continue until everything is picked up. Make sure you hide enough candies so that they will continue to find these little treasures as they clean up. In this morning's lesson, they will hear about a very special treasure that was discovered in the rubble of the temple.

 **Hidden Picture (Worksheet).** 🦋, 🦋 Have the students find the five hidden scrolls in the ruins, 2KG05.GF3.

 **Nebuchadnezzar and Babylon (Map/Discussion).** 🦋, 🦋 KG05.GF4 Pgs. 1 & 2 provide background information and a map that shows the Babylonian Empire under King Nebuchadnezzar.

---



### Book:

#### Presentation Ideas -

 **King Josiah Takes the Throne (Illustration/Coloring Page).** 🦋, 🦋 2 Kings 22:1, 2KG05.GF5.

 **The Five Scrolls Are Found (Illustration/Coloring Page).** 🦋, 🦋 2 Kings 22:8, 2KG05.GF6.

 **Josiah Hears the Words of the Law (Illustration/Coloring Page).** 🦋, 🦋 2 Kings 22:9-10, 2KG05.GF7.

 **Josiah Tears His Robes (Illustration/Coloring Page).** 🦋, 🦋 2 Kings 22:11, 2KG05.GF8.

 **Josiah and the People Make a Covenant with the Lord (Illustration/Coloring Page).** 🦋, 🦋 2 Kings 23:1-3, 2KG05.GF9.

 **Josiah Tears Down All the Altars of Baal (Illustration/Coloring Page).** 🦋, 🦋 2 Kings 23:4-14, 2KG05.GF10.

 **Scrolls (Role-play).** 🦋, 🦋 Roll up five pieces of large white construction paper. Put the names of the first five books of the Bible on the scrolls—one name per scroll. Put them in a large cardboard box with the ends sticking up. Put in a variety of other items: a lamp, silver serving trays, magazines, and anything else you might like. Once you have filled the box with the items, put a light coating of flour over everything. In class have different students take turns bringing things out of the box and dusting them off. Read the names on the scrolls as the students pull them out. This is essentially how the lost books were found. The priests were emptying out the temple treasury and found the first five books of the Bible hidden away inside.



**Lost and Found (Role-play).** 🐛, 🦋 Prior to class, prepare your Bible Adventure with notes written on a large scroll. Make a fancy scroll using butcher paper that is about 1 foot wide by 12 feet long with some type of tassels on the ends of the paper. Roll up the scroll and make it look old by painting tea on it. Prepare numerous boxes to look like bricks. Bring in some old boards to create a messy, rundown temple. While dressed as a king, look through the rubble and come across the scroll. (You may want to use a Bible if it would be better for the students to understand.) This is a great time to go into a full-blown acting dissertation, with weeping and wailing. Present the Bible Adventure from Josiah's point of view. If time permits, you may want the students to act out the scene during the Took time.

### ***Bible Adventure for K – 2<sup>nd</sup> Grades –***

Hezekiah had been a righteous king for the nation of Judah. He repaired the temple of the Lord and tore down all the centers of idol worship. When the Assyrians threatened to attack, Hezekiah prayed to God and trusted Him for protection. Even when he sinned, Hezekiah repented and humbled himself before the Lord. But the hope that Hezekiah brought to Judah quickly faded when he died and his son Manasseh took the throne. 2 Kings 21:2 says of him, "He did evil in the eyes of the LORD, following the detestable practices of the nations the LORD had driven out before the Israelites." And when he died, his son Amon was equally as wicked.

Amon was such a terrible king that he was killed by his own servants at the young age of 24. He had a son named Josiah who, at eight years old, became king in his father's place. Even though his father was wicked, Josiah loved the Lord deeply. At the age of 26, after 18 years of being king, he desired to rebuild the temple. The temple that Solomon had built had been neglected during the reigns of Manasseh and Amon. King Manasseh even built pagan altars in it and brought in idols. Since Manasseh and Amon did not love the Lord, they cared little about His temple. But Josiah loved God and wanted the temple restored so that the people might worship Him again.

Josiah took money that had been collected at the temple and paid workmen to repair the damages done to the temple. While the work was being done, they made an incredible discovery. They found the Book of the Law that Moses had written! One of the scribes then read the Scriptures to Josiah and after he heard the words of the Lord, he tore his clothes. Now why would he do that after hearing God's Word?

To tear one's clothing was a sign of great grief and despair. Josiah realized that the nation of Judah had totally rebelled against God's commands and deserved His punishment for their sins. He then asked the high priest to go and ask the Lord what He was going to do to the nation of Judah. After the priests went before the Lord, God gave Josiah the following message: God would indeed judge Judah for its repeated disobedience, but He would wait until after Josiah died because Josiah's "heart was responsive and [he] humbled [himself] before the LORD." (2 Kings 22:19).

Josiah then made a covenant with the Lord. He gathered all the people of Judah together and read them the Word of God. They committed themselves to walk in obedience to the commands of Scripture. Josiah demonstrated his willingness to keep his promise by tearing down all the altars to Baal and destroying all the items used for idolatry. He destroyed anything that had any association with pagan worship, including killing the idolatrous priests. Josiah completely did away with all the sinful idolatry that had polluted the land. He obeyed the commands of the Lord, and for the first time since the days of the judges, Judah celebrated the Passover exactly as the law had required.

Although Josiah made many positive changes and wanted to rule in obedience to God, the sins of Manasseh and the other kings were so great that God used the powerful nation of Babylon to punish Judah. The Babylonian king Nebuchadnezzar forced most of the people of Judah from their land and left only the poorest people to remain behind. King Nebuchadnezzar also took all the riches from the temple and the king's palace. In the end, the Babylonian army destroyed the temple and tore down the walls of the capital city of Jerusalem. They burned most of the city and took anything left of value. What a sad and tragic chapter in the history of Judah! But through all the sorrow and loss, God had not forgotten His promise that He had made to King David hundreds of years before: the descendants of David's family would survive and from them would come the promised Messiah—Jesus Christ.

Josiah's reign certainly was a bright spot in the history of the nation of Judah. When the Word of God was discovered during the temple repair, he knew that he had found the greatest of treasures! Judah had lived for over 50 years without God's Word, and they did not know what pleased God or what He

despised. Their own sinful choices left the people under the fierce anger of the Lord. But when Josiah heard the words of God, his heart was broken and humbled. This is just the way we should respond to the Word of God when we hear it or read it. Not only did Josiah humble his heart, he obeyed the Word and called the entire nation to obey it as well. It doesn't do any good to know the Bible but fail to obey what it says. Are there any areas in your life in which you are in disobedience to the Lord? If so, find out what God's Word says about your disobedience and how you can walk in obedience to Him.

The Bible is a priceless treasure! We should be extremely thankful to God that He has given us His complete and perfect truth. We don't need to look anywhere else to find the answers we need about life and our relationship with God.

### ***Bible Adventure for 3<sup>rd</sup> – 6<sup>th</sup> Grades –***

Nearly 50 years had passed since the time Hezekiah was the king of Judah. During his reign, the Lord protected Judah from an attack by the powerful Assyrians. Since that time, Assyria grew weaker and was no longer the strong nation it once was. The Babylonians became the most powerful people and destroyed the Assyrians in 609 B.C.

Spiritually, the nation of Judah had grown weak under the kings after Hezekiah. His son, Manasseh, rebuilt the high places and began to worship false gods. After Manasseh, his son Amon took the throne and was equally wicked. The hope that Hezekiah had brought quickly faded into the past with the reigns of these two men.

King Amon was killed by his own servants at the young age of 24. He had a son named Josiah who was eight years old at the time and became king in his father's place. Even though his father was wicked, Josiah loved the Lord deeply. At the age of 26, after 18 years of being the king, he wanted to rebuild the temple. The temple that Solomon had built had been neglected during the reigns of Manasseh and Amon. King Manasseh even built pagan altars in it and brought in idols. Since they did not love the Lord, they cared little about His temple. But Josiah loved God and wanted the temple restored so that the people might worship Him again.

He took the money that had been collected at the temple and paid workmen to repair the damages done to it. They made an incredible discovery while the work was being done. They found the Book of the Law that Moses had written! One of the scribes then read the Scriptures to Josiah and after he heard the words of the Lord, he tore his clothes. Now why would he do that after hearing God's Word? To tear one's clothes was a sign of great grief and despair. Josiah realized that the nation of Judah had totally rebelled against God's commands and deserved His punishment for their sins. He then asked the high priest to go and inquire of the Lord what He was going to do to the nation of Judah.

After the priests went before the Lord, God gave Josiah a message. The message was that God's judgment upon the nation would be withheld since Josiah had truly humbled himself before Him. Josiah would not see God's punishment upon Judah during his lifetime, but a later generation would instead.

Josiah then made a covenant with the Lord. He gathered all the people of Judah together and read them the word of God. They committed themselves to walk in obedience to the commands of Scripture. Josiah demonstrated his willingness to keep his promise by tearing down all the altars to Baal and items used for idolatry. He destroyed anything that had any association with pagan worship, even taking the lives of the idolatrous priests. Josiah completely did away with all the sinful idolatry that had polluted the land. He obeyed the commands of the Lord, and for the first time since the days of the judges, Judah celebrated the Passover exactly as the Law had prescribed.

Josiah instituted many good changes and desired to live and rule the nation based solely on the Word of God, but because the sins of Manasseh and the other kings were so great, God was going to punish the nation. The Babylonians came to Judah in 605 B.C. and carried some of its people away to Babylon (these included Daniel and the three Hebrew youths). For three years, Babylon controlled Judah and had the nation pay tribute money to king Nebuchadnezzar.

Eight years later, in 597 B.C., Nebuchadnezzar deported the majority of the people from the land and left only the poorest people to remain. King Nebuchadnezzar also took all the valuables from the temple, as well as the king's palace, and cut the gold into small pieces. Judah's king at the time was Jehoiachin. He

was taken away to Babylon as well. To replace him, Nebuchadnezzar appointed his uncle, a man by the name of Zedekiah.

Zedekiah thought he could somehow rebel against Babylon, but when he tried, Nebuchadnezzar brought his army and surrounded the city of Jerusalem. For two-and-a-half years, the city was under siege until famine drove the people to starvation. After that time, Babylon overtook the city, broke through the walls, and destroyed the fleeing army of Judah.

The Babylonian army then destroyed the temple and tore down the walls of Jerusalem. They also burned the important buildings and homes and deported all the people except for the poorest to Babylon. They looted the city and took any valuables that were left. These events took place in 586 B.C. Despite the sorrow and sadness of this tragedy in the history of Judah, the Lord was still merciful to the house of David and allowed his kingdom to survive.

Can you imagine living life without a Bible? This is the way the people of God lived for over 50 years. They did not know what pleased the Lord or what He despised. They were left to their own opinions of what would be best and right and good. Obviously, their own sinful choices left them under the fierce anger of God. He was not happy with His people because they totally disregarded His commandments found in Scripture. In fact, it was their disobedience to the law that eventually led to their downfall.

When Josiah heard the words of God, his heart was broken and humbled. This is just the way we should respond to the Word of God when we hear it or read it. Not only did Josiah humble his heart, he obeyed it and called the entire nation to obey it as well. It doesn't do any good to know the Bible but fail to obey what it says. Are there some areas of your heart that are in disobedience to the Lord? If so, find out what God's Word says about your disobedience and how you can walk in obedience to Him.

We should be extremely thankful for the Bible, which is a priceless treasure! God has given us His complete and perfect truth. We don't have to look anywhere else to find the answers we need about life and our relationship to God.

#### Aim Questions:

1. **Who was the last good king of Judah and how long did he reign?** *King Hezekiah; 29 years.*
2. **What nation became the world power after the Assyrians?** *Babylon.*
3. **How old was Josiah when he became king of Judah?** *8 years old.*
4. **What did Josiah command be done to the temple and why?** *He wanted it to be restored so that the people might worship the Lord again.*
5. **What did the workman find while repairing the temple?** *The Word of God ~ the law written by Moses.*
6. **What did Josiah do when he heard the Word of God?** *He tore his clothes and repented of his disobedience and humbled himself before God. He also tore down all the pagan altars and destroyed any items and people of idolatry.*
7. **In what year did Babylon destroy the city of Jerusalem?** *586 B.C.*
8. **What was the name of the king of Babylon at this time?** *Nebuchadnezzar.*



#### Look:



**Book of the Covenant (Worksheet).** 🦋 Josiah read the book of the covenant out loud to the nation of Israel. What exactly was this book? It was a section in the law in which God gave the Ten Commandments and other important rules for the people of Israel to follow (Exodus 20:1-23:33). Use this worksheet to discover some of the important features of this part of the law, **2KG05.GF11**.



**Josiah Tears Down the Idols (Worksheet).** 🦋 Josiah went on the most extensive purge of idolatry the country had ever known. He went throughout Judah and even into Israel to tear down the idols. Have your students look up the verses and write the places where Josiah tore down idols, **2KG05.GF12**.

**Wall/Scroll Puzzle (Craft).** 🦋, 🦋 Duplex-copy **2KG05.GF13 Pgs. 1 & 2** onto cardstock for each student. Ask the students to color their “wall” and outside of the scroll. Have them cut inside the border to make four to seven large puzzle pieces. Have them trade with their neighbors, taking turns putting together each other’s puzzle. When they have completed a puzzle they should practice the memory verse, saying it aloud.

**Wall Surprise (Craft).** 🦋, 🦋 Each student will need:

1 pie box  
**2KG05.GF14 Pgs. 1 & 2**  
packing tape  
glue  
coloring crayons

Before class preparation: 1) Glue a scroll page to the inside of each pie box (box should still be flat when finished); 2) Glue the wall page to the outside of each box; 3) Put a small slit in the center of the hole in the wall (so that the student will be able to get scissors in the slit to cut out the hole).

During class: 1) Have each student color the wall picture (not the hole) on the box as they practice the memory verse; 2) When the student is finished, help him/her fold the box (packing tape will hold it together better than glue); 3) Have the student cut out the hole—the surprise scroll is inside!

**Idols in Our Lives (Worksheet/Coloring Page/Discussion).** 🦋, 🦋 Copy **2KG05.GF15** for each student. Ask the students to circle the pictures that show activities or items that they do, have, or think about. Discuss how these things can sometimes become idols in our lives—things we put before and love more than we love God. Just as Josiah had the people destroy the idols in their land, we should rid our lives of idols. Ask the students to draw a box around the one picture on the page that should be their priority over the others.



**Dust Your Bible (Relay Race).** 🦋, 🦋 Organize your classroom and the students for a relay race. Prepare materials for the following four activities out of today’s Bible lesson. As you explain to the students the expectations for each of these relay activities, review the significance of each action as it pertains to the Bible story. 1) Blow the dust off your Bible. Spread a teaspoon of flour over a Bible set on a chair or table. Each team should have a corresponding Bible and chair. Students must run up to the Bible and blow all of the flour off it before returning to the next person in line, who, once tagged, will run to the Bible and do the same (after a teacher replenishes it with a new teaspoon of flour). – Ask why the scrolls had dust on them. 2) Tear your clothes. Don’t instruct students to do this until they realize that the clothing that they are to rip is an old sheet with a slit in the middle for a head, as with a Mexican poncho. The students will run up to this “garment” and place it over their heads before ripping the bottom hem approximately 12 inches. Teachers should prime this sheet with slight niches along the bottom for easy tearing. – Ask why Josiah tore his clothes. 3) Read the law aloud. Roll up a piece of butcher paper tightly on both ends after writing a couple of verses of the Mosaic law (e.g., Exodus 20) on it. The students will run up to this scroll, unroll it, and read it in a loud voice to his or her team before running back to the next person. – Ask why Josiah read the Law aloud. 4) Prostrate yourself humbly. Teach the students exactly what it means to prostrate oneself. Leaving some room beyond the chair that holds the Bible, cloth, and scroll, have the students run past the chair to prostrate themselves completely before returning to the team. – Ask why we prostrate ourselves.

**Hidden Message (Word Search).** 🦋, 🦋 Explain that Scripture is profitable for us in many ways. Have the students follow the arrows and write the letters in the space provided, **2KG05.GF16**.

**Young King Josiah (Worksheet).** 🦋, 🦋 Use **2KG05.GF17** to have the students learn more about this very godly leader and how he taught the people of Judah the importance of the Word of God. What’s even better is that we, too, can learn from him today!

**Aim Questions (Worksheet).** 🦋 Have the students answer the Aim Questions about today’s Bible Adventure, **2KG05.GF18**.



**Passage Review Questions (Worksheet).** 🦋, 🦋 This booklet contains many questions from the Scripture passage covered in today’s lesson. Students may work on them in class and complete them during the week at home, **2KG05.GF19**.



 **2 Kings 18:6 (Memory Verse Song).**  Words and music for today's memory verse are available upon request from Children's Ministry.

---



**Took:**

 **Life's Treasure Chest (Craft).**   Have the students color and decorate the boxes provided by Children's Ministry to look like treasure chests. Write inside the lid "The Bible, God's Words for Us." On the outside of the treasure chest, write the words "Life's Treasure." Encourage the students to read their Bibles every day this week, and copy down Scripture passages and deposit them in their treasure chest. They can use this to keep their memory verses, devotionals, or perhaps a smaller Bible. Refer to **2KG05.GF20** for dimensions, cutting, and folding instructions. A finished sample of the treasure chest is on display for your reference.

 **Tumbled Temple Treasure (Craft).**   While doing this craft, talk to the students about how Josiah found the Book of the Law that had been lost for many years and how excited he was to follow God's Word when he found it. Each student will need:

8" sturdy paper plate

10-12 sugar cubes



4-6 small wooden dowels (provided by Children's Ministry)



verse and Ten Commandments labels from **2KG05.GF21**

markers or crayons

Tacky or Elmer's glue (glue sticks will not work on this craft)

Have the students build a broken-down temple with pillars (dowels) and finely crafted stones (sugar cubes) by gluing them onto the top of an inverted paper plate. They may use crayons or markers to add the creative touch. Have them cut out the Bible verse and glue to the base of the plate. Finally, have the students roll up the Ten Commandments into little scrolls and place in the temple.

 **Clean the Inside and Out (Craft/Discussion).**   Discuss with the students how Josiah did more than any other king in getting rid of idols. No king followed God closer than Josiah. However, the people in Judah still had idolatry in their hearts. They needed their souls cleansed. Give each student a little bar of soap and a sticker from **2KG05.GF22 (Avery Label #5160)** as a reminder that they, too, need to keep their hearts pure before God, using His Word as a cleansing agent in their lives.

 **Advent Calendar – Scroll-A-Day (Craft).**   Each student will need:

- a set of commandments and verses from **2KG05.GF23 Pg. 1**
- 2KG05.GF23 Pg. 2**
- coloring crayons
- scissors
- glue or double-stick tape

Have the students cut the commandments and verses apart. Have them roll up each of the seven slips of paper, starting at the bottom, like a scroll. When they have finished rolling up all of their slips, they should put a dot of glue or a small piece of double-stick tape on each X and attach one scroll to each X. They will have one commandment or verse to unroll each day this week.



**Find the Bible (Game).** 🎲 Have the students sit on their knees in a circle around another student (Josiah). Review the portions of the Bible Adventure where they learned about how the Book of the Law had been lost, when it was found, and when it was read to all of the Israelites. Instruct the student in the center of the circle to cover his eyes while the other students, with their hands behind their backs, pass the Bible around in the circle. While they are doing this, they all say:

Josiah, Josiah,	God's Words to us,
The Bible is Lost!	It's hard to measure,
We must find it,	So special to all,
Whatever the cost.	Life's real treasure.

At the conclusion of this rhyme, "Josiah" may open his eyes and try to guess who has the Bible behind his or her back. He may have three guesses to find the Bible. If he makes the correct choice, that student then gets to be "Josiah" in the center. If he chooses incorrectly, he must stay in the center of the circle for another turn.



**Renewing Our Covenant (Prayer/Discussion/Craft).** 🎲, 🎨 Each student will need:

- 2KG05.GF24 copied onto white paper
- 1 sheet of light-colored construction paper
- 1 sheet of dark-colored construction paper
- 1 tea bag
- tape
- glue
- 18-inch piece of yarn

Talk to the students about what it means to make a promise (covenant). Review how Josiah read the Book of the Law before the people, and they renewed their covenant to obey God. Pray as a group that all would hold fast to the Word of God, stay close to Christ through prayer and worship, and would live obediently before Him in everything we do.

**Craft Instructions:** Have the students dab a barely-moistened tea bag on the scroll from 2KG05.GF24. Have them cut it out in a scroll shape and paste it on the light-colored piece of construction paper. Have the students cut the dark-colored construction paper in half lengthwise and roll each piece into a long tube shape. These will be the scroll ends. Use tape to secure the ends of the rolls. Glue (allowing time to dry) these rolls at the top and bottom of the covenant. Attach a yarn through the top roll so that this can be hung as a reminder to be obedient to the Word of God. If you want to omit making the construction paper rolls you can simply hang the covenant with a piece of yarn attached to the back. As the students assemble this craft, talk about specific and practical ways that they might steer clear of the temptations leading them away from God.



**Precious Jewels (Craft).** 🎲 Each student will need:

- 2KG05.GF25 copied onto cardstock
- sequins
- glue
- 18-inch piece of yarn
- hole punch
- scissors

Have the students cut out the scroll and punch holes at the top through which to string the yarn through. Have them tie both ends into a knot. Next, have them glue the sequins to the beginning of each verse. They may hang the scroll up as a reminder that God's Word is a priceless treasure. They may also wear it around their necks.

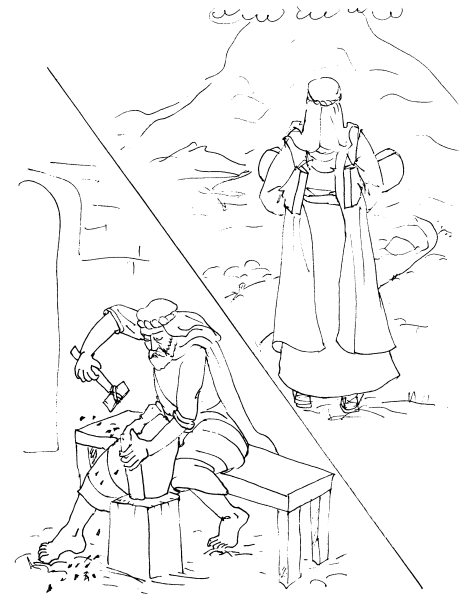
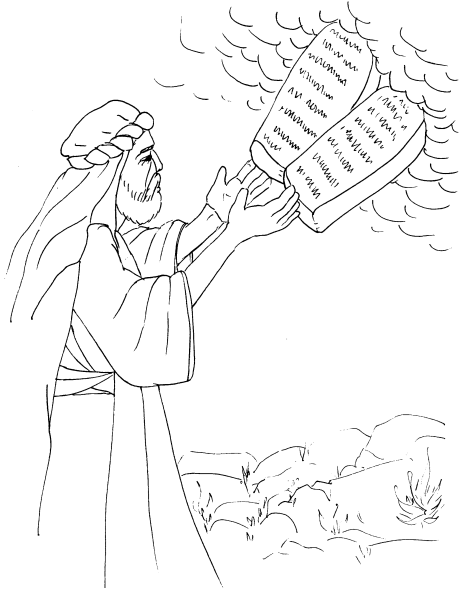

# The Book of the Law

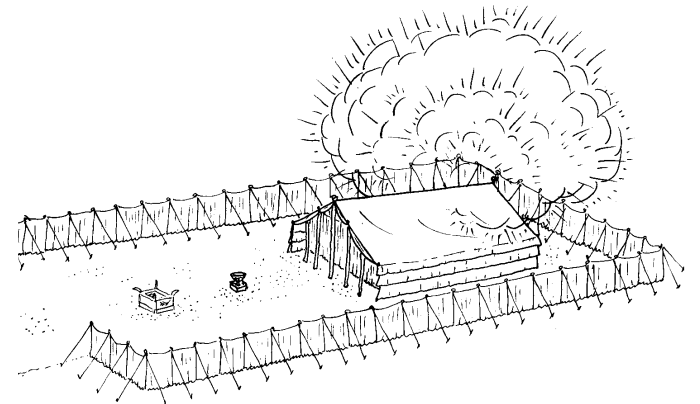
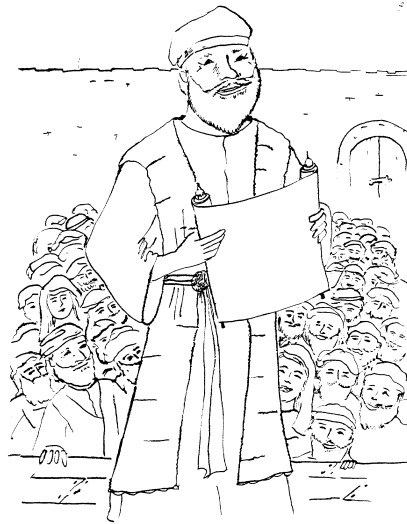
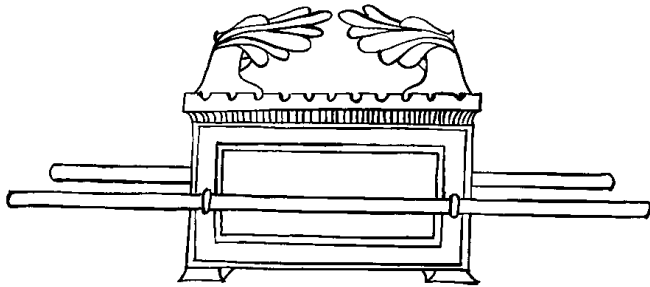
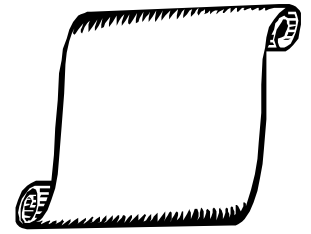
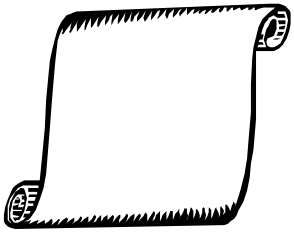

Treasure Hunt Clue #1

**WORDS FOR LIFE**

Treasure Hunt Clue #1

**WORDS FOR LIFE**

Treasure Hunt Clue #2

**Search for the pencil that  
makes no mistakes.**

Treasure Hunt Clue #2

**Search for the pencil that  
makes no mistakes.**

Treasure Hunt Clue #3

**The Breath  
of God**

Treasure Hunt Clue #3

**The Breath  
of God**

Treasure Hunt Clue #4

**T N T**

Treasure Hunt Clue #4

**T N T**

Treasure Hunt Clue #5

**2 Timothy 3:16-17**

Treasure Hunt Clue #5

**2 Timothy 3:16-17**

# Treasure Hunt Set Up and Clue Placement for Teachers

## #1 WORDS FOR LIFE

Write the words “without error” on the whiteboard with scrambled letters. The students should see this and know to go to a Bible for the next clue.

## #2 FIND THE PENCIL THAT NEVER MAKES MISTAKES

Hide an eraserless pencil somewhere in the room with clue #3 attached. You will need to do this before class. Make sure that it is in plain view but not obvious.

## #3 BREATH OF GOD

Have a sign with a roll of breath mints glued to it with a large diagonal slash through it. God does not need breath mints. The fourth clue should be written on the back of the sign.

## #4 TNT

Somewhere in the room put either a drawing or a fabricated stick of dynamite (toilet paper or paper towel tubes will work great). Write your next clue on the side of the stick of dynamite. “Trusted and True” - Manual for “Good Works.” Place a stack of tools, tool box, and work gloves in a corner of the classroom. This will be where the students must go for their last clue.

## #5 2 TIMOTHY 3:16-17

This is the final clue. They will need to use their Bibles to look this verse up. Place a Bible off by itself but in plain view and see if the students will go to it to find their treasure. Place inside the front cover of the Bible a sign that says “This is life’s treasure. You have found it!” As a reward, you might give additional instructions as to where they might go to receive this reward. Consider a piece of hard candy, a chocolate coin candy, or stickers for the reward.

Remember to encourage the students to work quietly and not let the others in on the answers to the clues. This way everyone can work at his or her own pace. The important part comes during the Bible Adventure when the teacher can ask, “What is our life’s treasure?”

# Hidden Picture

Find the five hidden scrolls in the ruins.

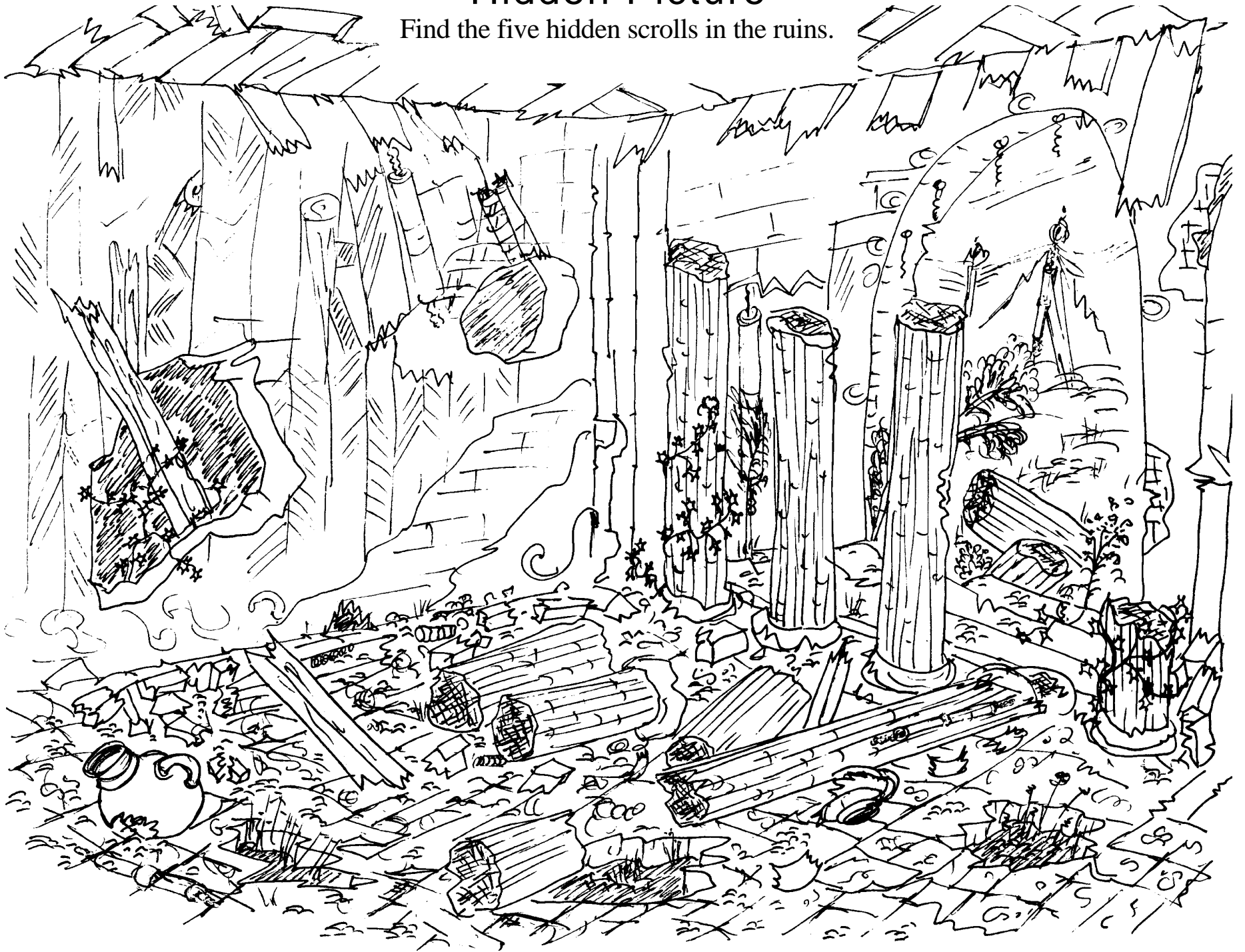

# Nebuchadnezzar and Babylon

The monumental list of Babylon's kings reaches back to 2300 B.C. and includes Khammurabi, or Amraphel, the contemporary of Abraham. Babylon stood on the Euphrates, about 200 miles above the river's junction with the Tigris, which flowed through Babylon's midst and divided it into two almost equal parts. This city gradually grew in extent and grandeur but, in process of time, became subject to Assyria. Upon the fall of Nineveh (606 B.C.), Babylon threw off the Assyrian yoke, and became the capital of the growing Babylonian empire. Under Nebuchadnezzar it became one of the most splendid cities of the ancient world.

Nebuchadnezzar was the son and successor of Nabopolassar, who delivered Babylon from its dependence upon Assyria and laid Nineveh in ruins. He was the greatest and most powerful of all the Babylonian kings. Necho II, the king of Egypt, gained a victory over the Assyrians at Carchemish. This secured to Egypt the possession of the Syrian provinces of Assyria, including Palestine. The remaining provinces of the Assyrian empire were divided between Babylonia and Medea. But Nabopolassar was ambitious in reconquering from Necho the western provinces of Syria, and for this purpose he sent his son Nebuchadnezzar with a powerful army westward (Daniel 1:1). The Egyptians met him at Carchemish, where a furious battle was fought, resulting in the complete rout of the Egyptians, who were driven back (Jeremiah 46:2-12) and Syria and Phoenicia were brought under the sway of Babylon (606 B.C.) From that time "The king of Egypt did not march out from his country again" (2 Kings 24:7). Nebuchadnezzar also subdued the whole of Palestine, and took Jerusalem, carrying away captive a great multitude of the Jews, among whom were Daniel and his companions (Daniel 1:1). Three years after this, Jehoiakim, who had reigned in Jerusalem as a Babylonian vassal, rebelled against the oppressor, trusting for help from Egypt (2 Kings 24:1). This led Nebuchadnezzar to send an army again for the conquest of Jerusalem, which at once yielded to him (598 B.C.). A third time he came against it, and deposed Jehoiachin, whom he carried into Babylon, with a large portion of the population of the city and the sacred vessels of the temple, placing Zedekiah on the throne of Judah in his stead. He also, heedless of the warnings of the prophet Jeremiah, entered into an alliance with Egypt, and rebelled against Babylon. This brought about the final siege of the city, which was at length taken and utterly destroyed (586 B.C.). Zedekiah was taken captive, and had his eyes put out by order of the king of Babylon, who made him a prisoner for the remainder of his life.

Modern research has shown that Nebuchadnezzar was the greatest monarch that Babylon, or perhaps the East generally, ever produced. He must have possessed an enormous command of human labor, nine-tenths of Babylon itself, and nineteen-twentieths of all the other ruins that, in almost countless profusion, cover the land, are composed of bricks stamped with his name. He appears to have built or restored almost every city and temple in the whole country. His inscriptions give an elaborate account of the immense works which he constructed in and about Babylon itself. Nebuchadnezzar died in 562 B.C., in the eighty-third or eighty-fourth year of his age, after a reign of forty-three years, and was succeeded by his son Evil-Merodach.

Information taken from the Revised Easton's Bible Dictionary

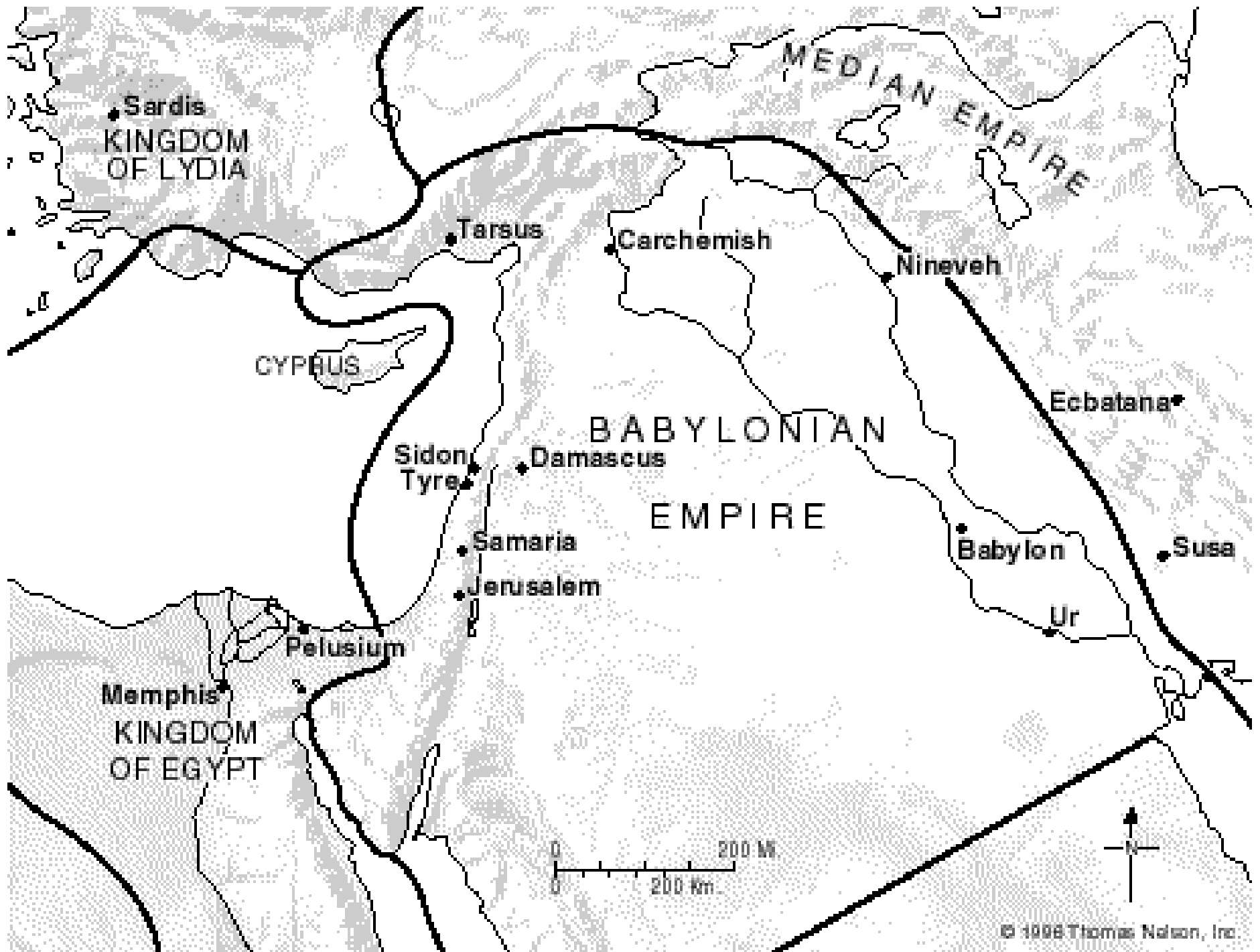

# King Josiah Takes the Throne



# The Five Scrolls Are Found



# Josiah Hears the Words of the Law



# Josiah Tears His Robes

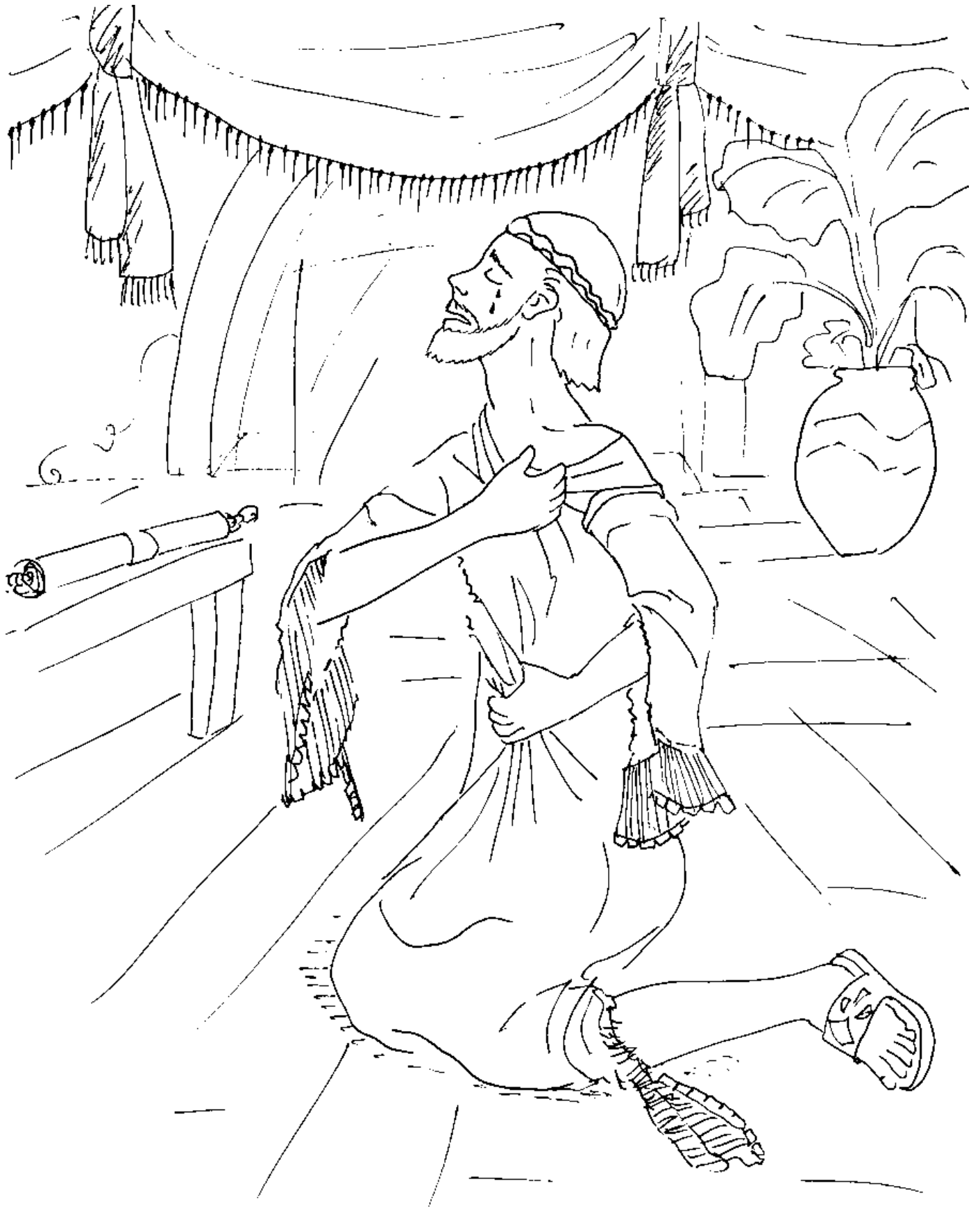

# Josiah and the People Make a Covenant with the Lord

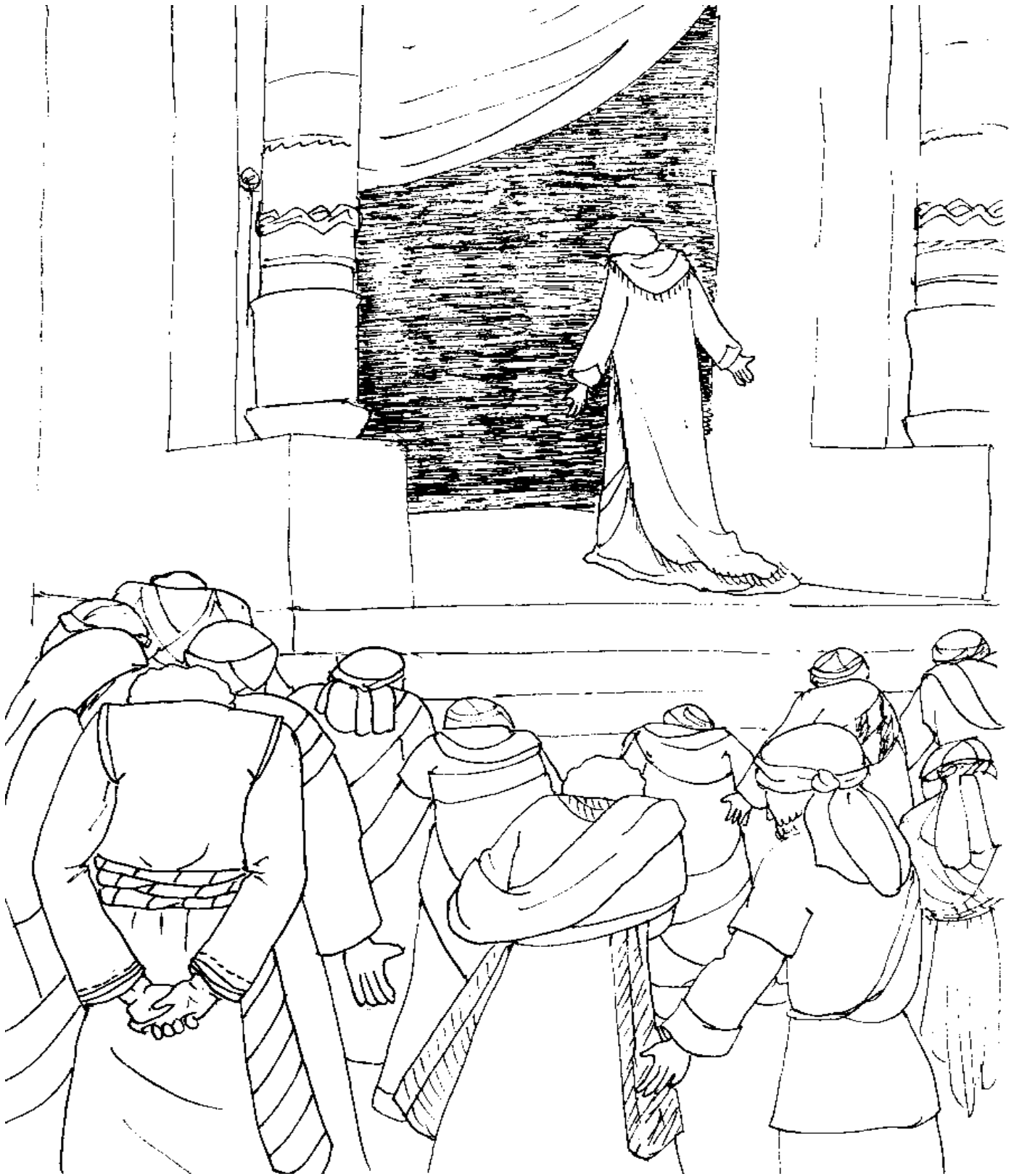

# Josiah Tears Down All the Altars of Baal

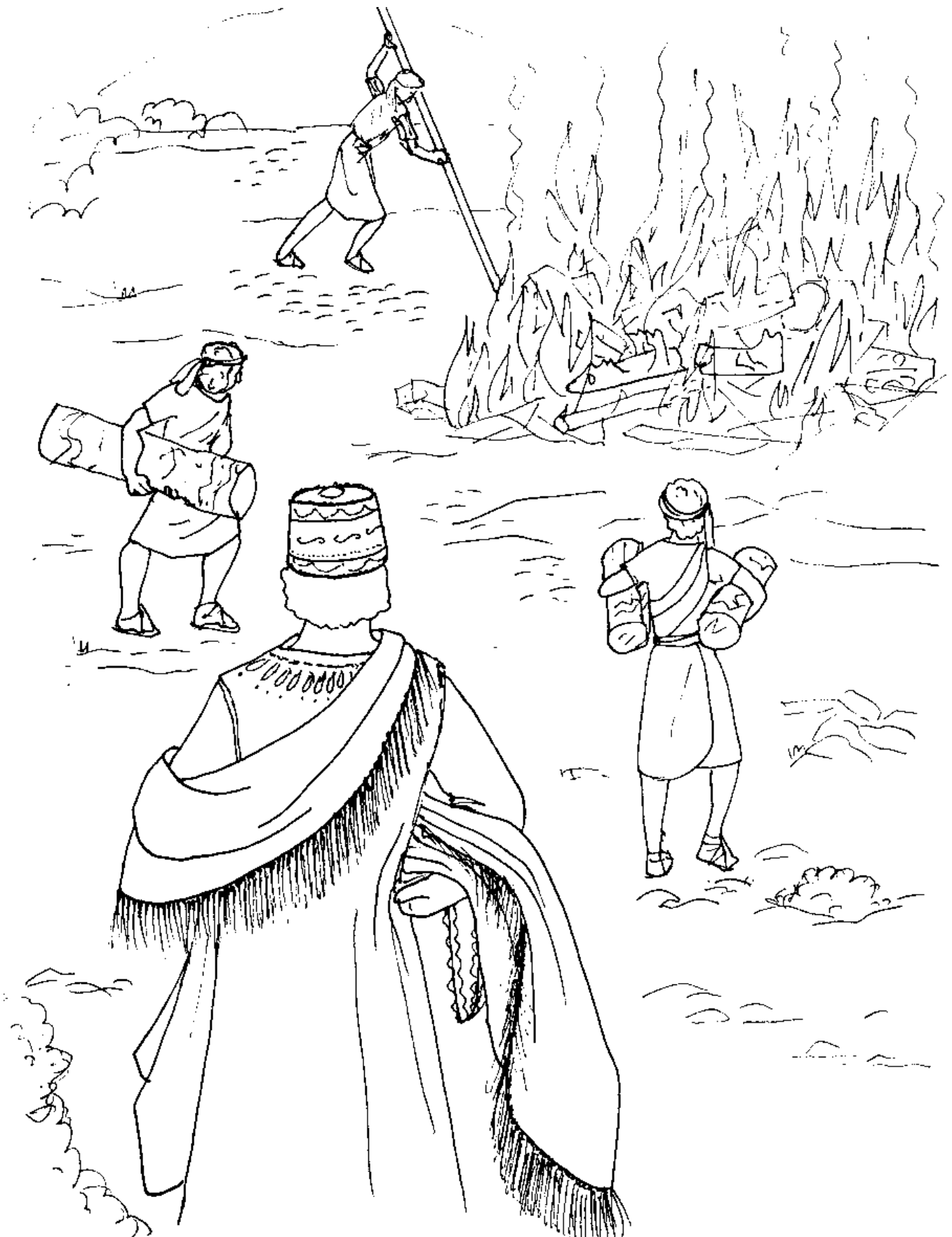

# Book of the Covenant



**The Book of the Covenant** was a special part of the “law” or first five books of the Bible. A covenant is an agreement between two nations or people. Complete these exercises and find out what the people in Josiah’s time were agreeing to do.

- 1. Read Exodus 24:7.** What did Moses read?
- 2. Quickly skim the titles of the sections from Exodus 20:1-23:33.**  
What kinds of things did God ask the people to do?
- 3. Carefully read Exodus 20:1-17.**  
What is the common name for these commands?  
Write out the 10 major commands.
- 4. Look through the rest of the section from chapter 20 to 23 and find some of the commands that expand on the ten commandments?**
- 5. Read Leviticus chapter 26:14-33.**  
What would happen if Israel disobeyed?
- 6. Why do you think Josiah ripped his clothes after hearing the law read to him?**

# Josiah Tears Down the Idols

Read the following passages and find all the places Josiah went to tear down the high places. Look at a map in the back of your Bible and locate as many as possible.

**2 Kings 23:5**

**2 Kings 23:6**

**2 Kings 23:8**

**2 Kings 23:10**

**2 Kings 23:12,13**

**2 Kings 23:15,19**

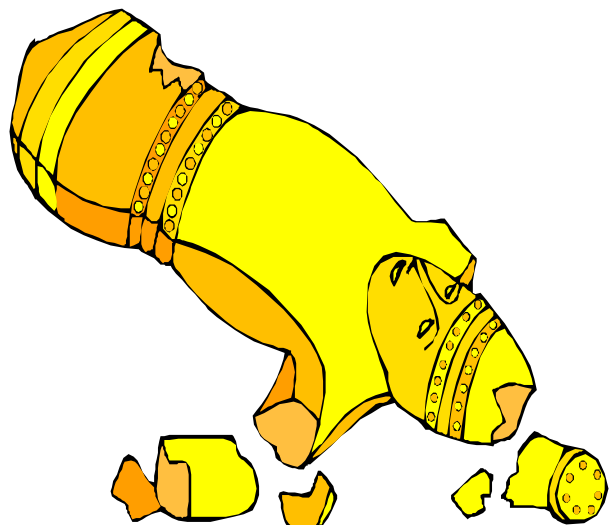

**"He held fast to  
the LORD and did  
not cease to  
follow him; he  
kept the  
commands the  
LORD had given  
Moses"  
2 Kings 18:6**

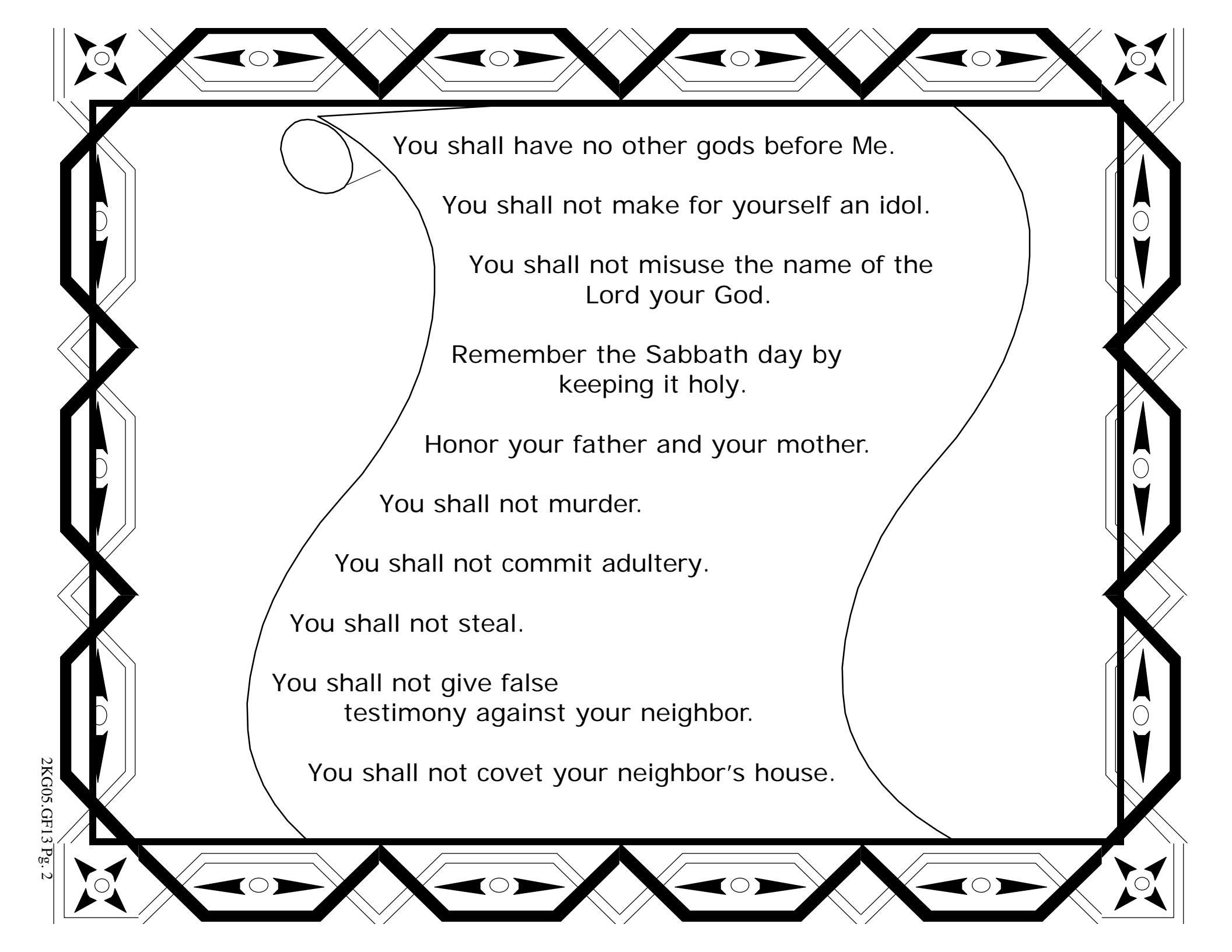

You shall have no other gods before Me.

You shall not make for yourself an idol.

You shall not misuse the name of the  
Lord your God.

Remember the Sabbath day by  
keeping it holy.

Honor your father and your mother.

You shall not murder.

You shall not commit adultery.

You shall not steal.

You shall not give false  
testimony against your neighbor.

You shall not covet your neighbor's house.

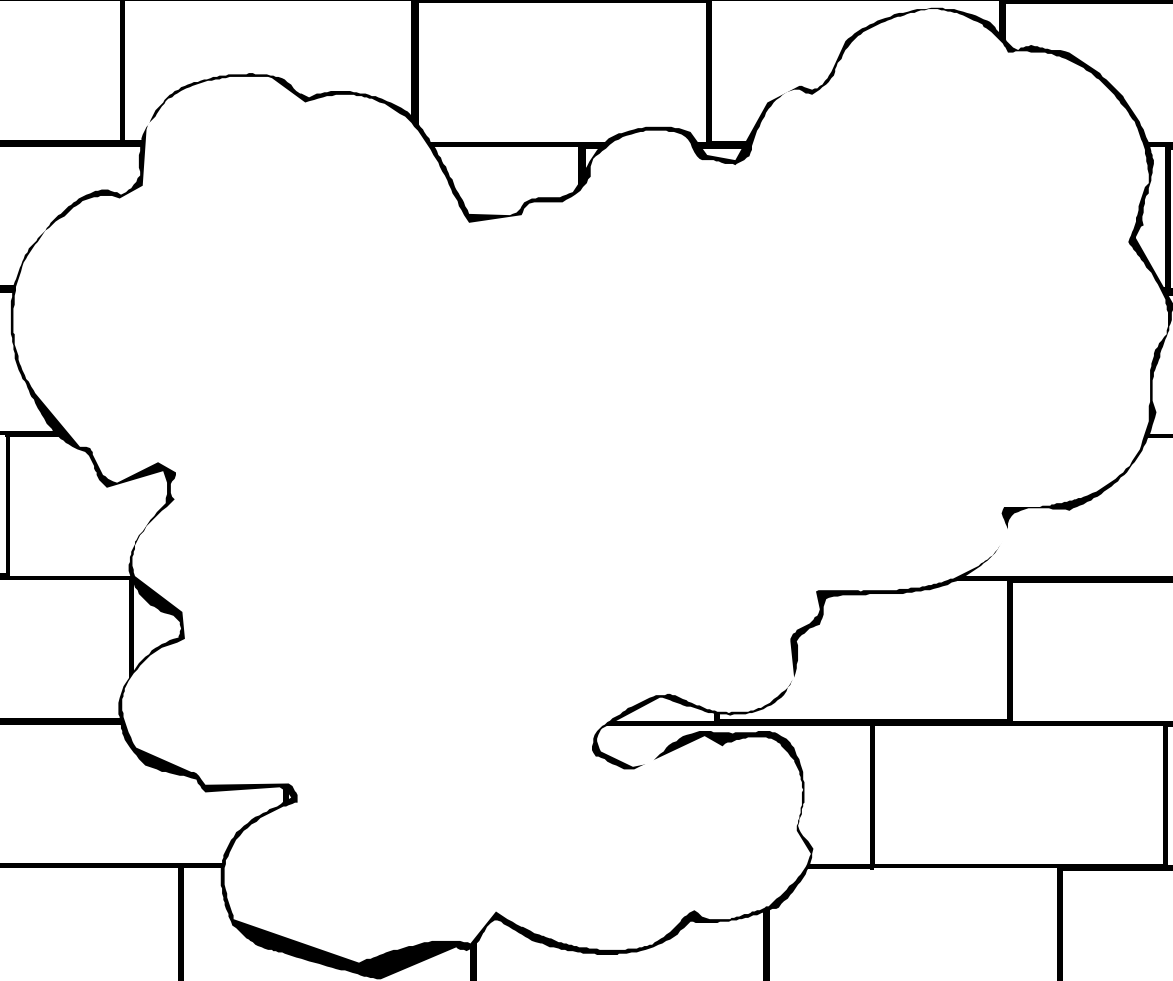

"He held fast to the LORD and did not cease to follow Him;  
he kept the commands the LORD had given Moses." 2 Kings 18:6

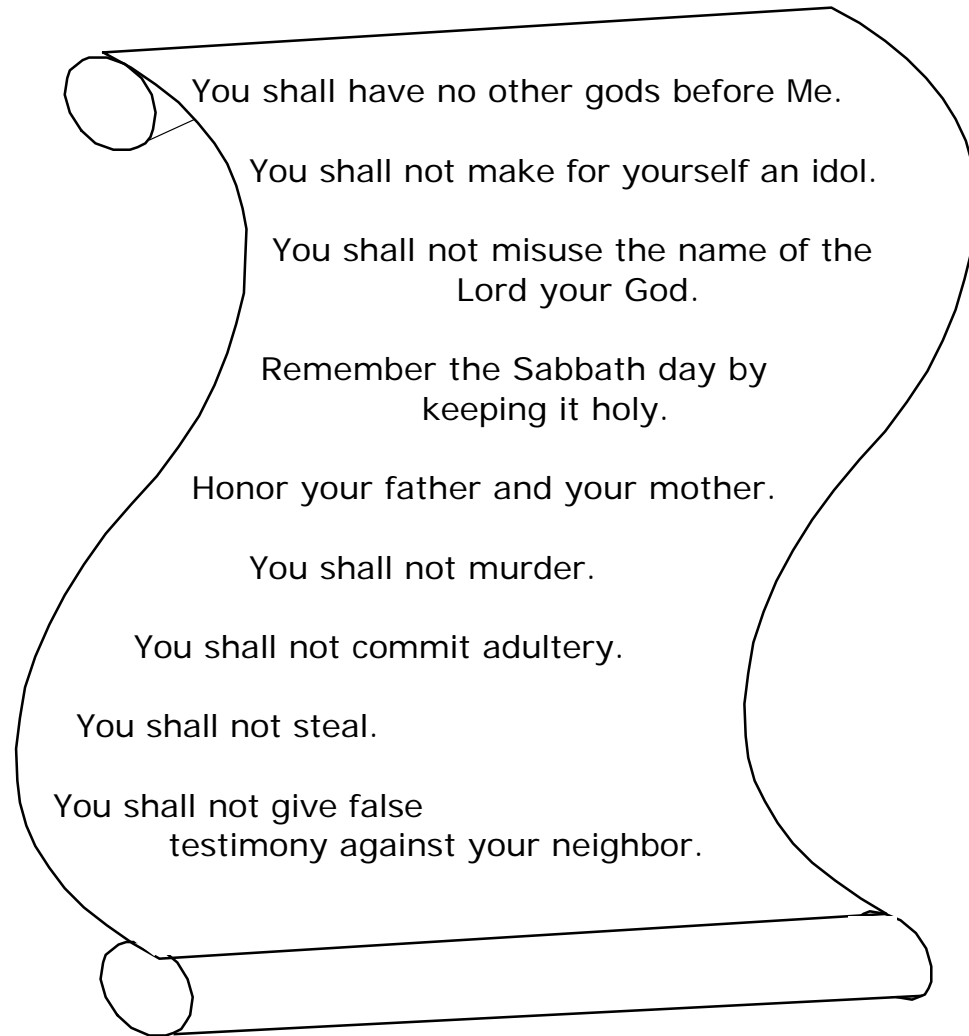

You shall have no other gods before Me.

You shall not make for yourself an idol.

You shall not misuse the name of the  
Lord your God.

Remember the Sabbath day by  
keeping it holy.

Honor your father and your mother.

You shall not murder.

You shall not commit adultery.

You shall not steal.

You shall not give false  
testimony against your neighbor.

Cut on dotted  
lines to make  
the scroll the  
correct size to  
fit in the pie  
box.

Glue to the  
inside of the  
box.

# Idols in Our Lives

Josiah pleased the Lord when he had the people destroy all the idols in the land. It pleases God when we rid our lives of the idols we have.

Cross out the pictures of the things that are possible idols in your life.  
Pray that the Lord will help you to put Him before all other things.

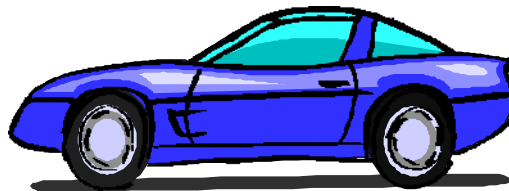
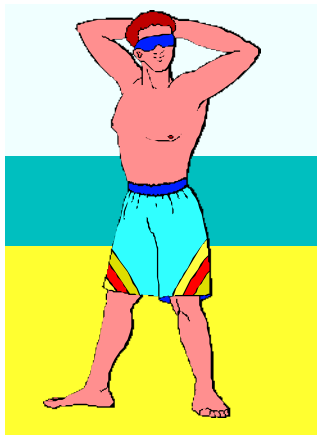
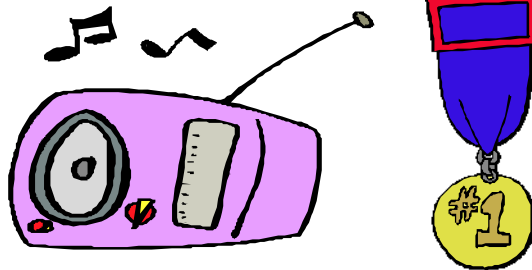
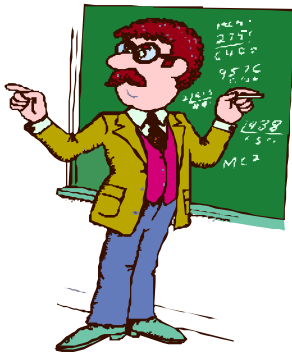
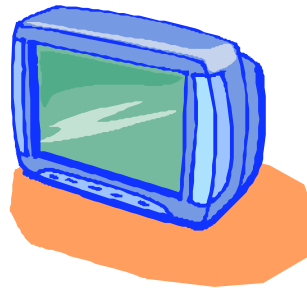
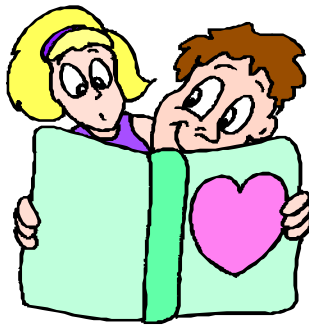
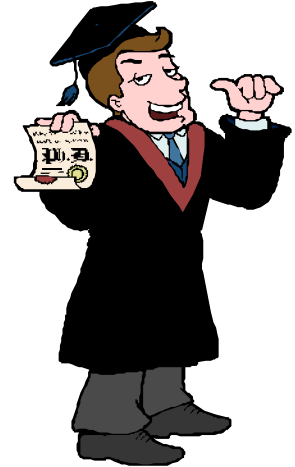

### Hidden Message

Follow the arrows and write the letters in the space below to find the message .

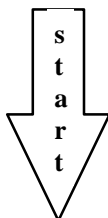

H	a	n	o	w	n	d	e	n
e	d	d	l	H	a	s	v	M
h	r	d	l	i	m	t	i	o
e	o	i	o	m	m	h	g	s
l	L	d	f	;	o	a	d	e
d	e	n	o	h	c	t	a	s
f	h	o	t	e	e	t	h	.
a	t	t	e	k	h	h	d	
s	o	c	s	e	t	e	r	
t	t	e	a	p	t	L	o	

Write the message here.

# Young King Josiah

Fill in the correct word from the word list to the right.

\_\_\_\_\_ was Josiah's great great-great-grandfather and was the last God-fearing king before Josiah.

Josiah became king at the age of \_\_\_\_\_.

Even though his father was \_\_\_\_\_, Josiah loved God.

Josiah desired to rebuild the \_\_\_\_\_.

While the men were repairing the temple,

\_\_\_\_\_ was found in the rubble.

Josiah \_\_\_\_\_ when the scribe read the Word of God.

Josiah obeyed God and destroyed many of the places of \_\_\_\_\_ worship which had been set up by previous kings.

The \_\_\_\_\_ celebration was reintroduced and worship was centralized in \_\_\_\_\_.

Just like Josiah, we should be \_\_\_\_\_ and \_\_\_\_\_ when our sin is revealed.

Josiah and the people of Judah made a \_\_\_\_\_ with the Lord promising to obey His commands.

Although Josiah was a righteous king, Judah still suffered the consequences brought on by the wicked kings who ruled before him. They were taken from their homes and held captive in



## What Can We Learn From King Josiah?

Look up these verses and discuss them in light of our Bible Adventure today. How did Josiah respond to the Lord when he realized his sinfulness? What was it that helped him to see how far they had wandered away from God's standards? How can we remember God's commands? How do we respond when we are confronted with our own sins?

Deuteronomy 6:1-9

2 Kings 21:24-26

2 Kings 22:2

2 Kings 22:11

2 Chronicles 34:3-4

2 Chronicles 34:27

Proverbs 1:7

John 8: 50-51

Colossians 3:5-6

1 Peter 5:5d-6

James 1:22

1 John 5:21

This next week, read Psalm 103 every day and consider God's goodness and mercy to those who love and obey Him. Pray for perseverance in staying close

## Word List

Use these words to complete the sentences to the left.

idol

Babylon

The Book of the Law

Passover

a bag of coins

a Thanksgiving feast

heart-broken

Shalom

twenty-six

listened carefully

covenant

twenty

tore his clothes

wicked

eight

Hezekiah

Manasseh

wicked

Jerusalem

Judah

temple

humble

repent

# Aim Questions

Answer the following questions about today's Bible Adventure.

1. Who was the last good king of Judah, and how long did he reign?
2. What nation became the world power after the Assyrians?
3. How old was Josiah when he became king of Judah?
4. What did Josiah command be done to the temple and why?
5. What did the workmen find while repairing the temple?
6. What did Josiah do when he heard the Word of God?
7. In what year did Babylon destroy the city of Jerusalem?

We should be extremely thankful for the Bible, which is a priceless treasure! God has given us His complete and perfect truth. His ways are best and right for everyone. We don't have to look anywhere else to find the answers we need about life and our relationship with God.



"He held fast to the LORD and did not cease to follow him; he kept the commands the LORD had given Moses." 2 Kings 18:6

## Passage Review Questions

2 Kings 22 - 25

After Amon was killed, who became king? (21:26b)

How old was Josiah when he became king? (22:1)

Was Josiah a good king or bad king? (22:2)

What lost book did Hilkiyah find in the temple? (22:8)

What did King Josiah do when he heard the words of the book read aloud? (22:11)

Why did King Josiah tear his clothes? (22:13)

What was God's judgment on Israel because of their continued disobedience? (22:16-17)

What was Josiah's heart like toward the God of Israel? (22:19)

Into what covenant did Josiah and the people enter with God? (23:3)

Who was the high priest at this time? (23:4)

How did Josiah respond to all of the "high places" and idolatry going on in Jerusalem? (23:4-6)

How did Josiah treat all of the evil priests? (23:20)

What was begun again when it was found in the Book of the Covenant? (23:21-23)

How many kings after Josiah responded with the same type of brokenness over sin? (23:25)

How did Josiah die? (23:29)

Who became king after Josiah died? (23:30)

What nation conquered and deported Jerusalem? (24:10, 14)

How long was Zedekiah and Jerusalem besieged by Nebuchadnezzar, the Babylonian king? (25:1-2)

What happened to Solomon's palace and the temple that Solomon had built for the Lord? (24:8,9)

What happened to all of the temple instruments, the Sea, and

# Life's Treasure Chest

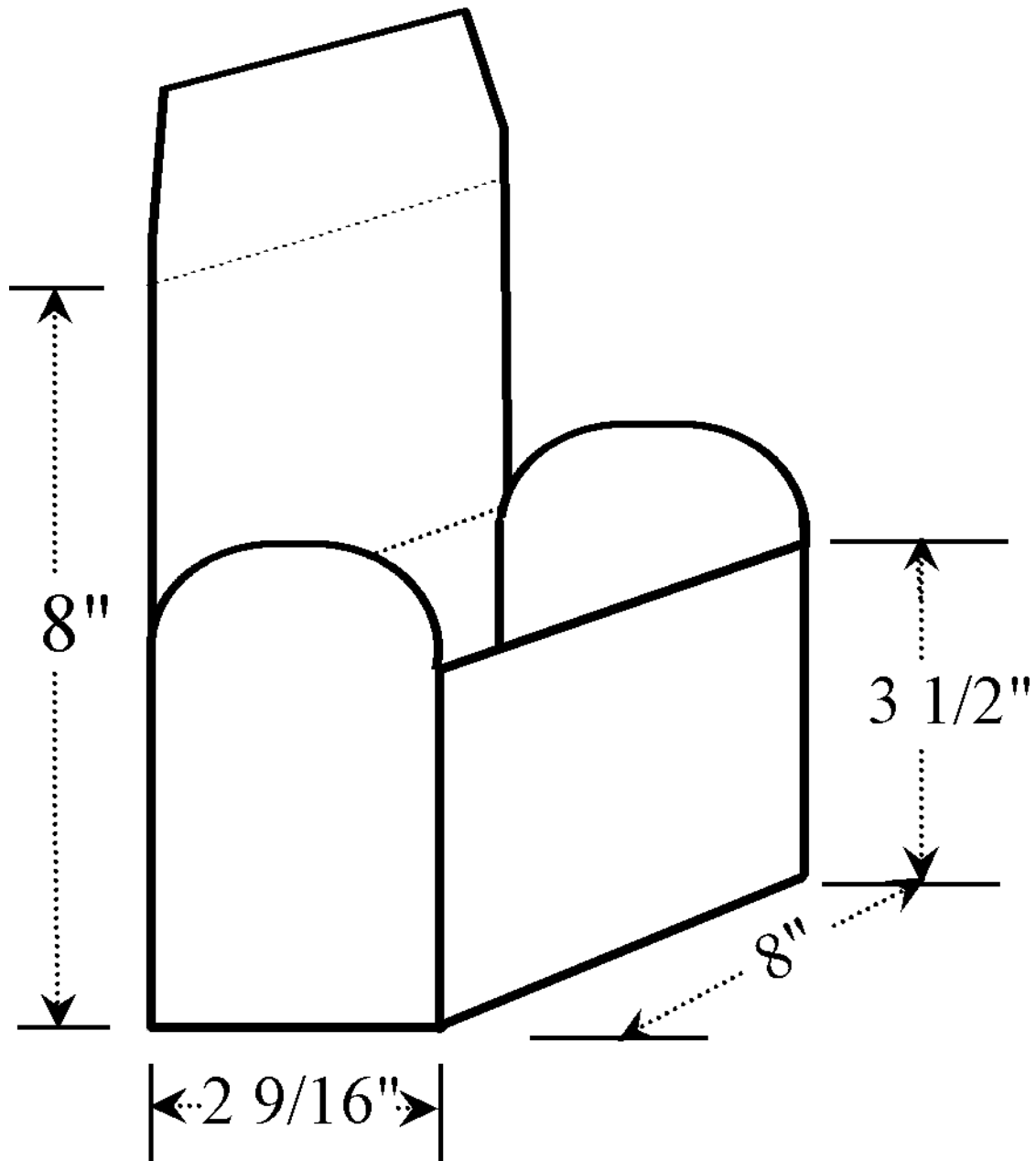

"I have found the Book of the Law in the temple of the Lord."  
2 Chronicles 34:15

"I have found the Book of the Law in the temple of the Lord."  
2 Chronicles 34:15

"I have found the Book of the Law in the temple of the Lord."  
2 Chronicles 34:15

"I have found the Book of the Law in the temple of the Lord."  
2 Chronicles 34:15

"I have found the Book of the Law in the temple of the Lord."  
2 Chronicles 34:15

"I have found the Book of the Law in the temple of the Lord."  
2 Chronicles 34:15

"I have found the Book of the Law in the temple of the Lord."  
2 Chronicles 34:15

"I have found the Book of the Law in the temple of the Lord."  
2 Chronicles 34:15

"I have found the Book of the Law in the temple of the Lord."  
2 Chronicles 34:15

"I have found the Book of the Law in the temple of the Lord."  
2 Chronicles 34:15

No other gods.	No idols.	No misuse of Gods name.	Keep the Sabbath holy.	Honor parents.	No murder.	No adultery.	No stealing.	No lying.	No coveting.
No other gods.	No idols.	No misuse of Gods name.	Keep the Sabbath holy.	Honor parents.	No murder.	No adultery.	No stealing.	No lying.	No coveting.
No other gods.	No idols.	No misuse of Gods name.	Keep the Sabbath holy.	Honor parents.	No murder.	No adultery.	No stealing.	No lying.	No coveting.
No other gods.	No idols.	No misuse of Gods name.	Keep the Sabbath holy.	Honor parents.	No murder.	No adultery.	No stealing.	No lying.	No coveting.
No other gods.	No idols.	No misuse of Gods name.	Keep the Sabbath holy.	Honor parents.	No murder.	No adultery.	No stealing.	No lying.	No coveting.
No other gods.	No idols.	No misuse of Gods name.	Keep the Sabbath holy.	Honor parents.	No murder.	No adultery.	No stealing.	No lying.	No coveting.
No other gods.	No idols.	No misuse of Gods name.	Keep the Sabbath holy.	Honor parents.	No murder.	No adultery.	No stealing.	No lying.	No coveting.
No other gods.	No idols.	No misuse of Gods name.	Keep the Sabbath holy.	Honor parents.	No murder.	No adultery.	No stealing.	No lying.	No coveting.
No other gods.	No idols.	No misuse of Gods name.	Keep the Sabbath holy.	Honor parents.	No murder.	No adultery.	No stealing.	No lying.	No coveting.
No other gods.	No idols.	No misuse of Gods name.	Keep the Sabbath holy.	Honor parents.	No murder.	No adultery.	No stealing.	No lying.	No coveting.



<p>You shall have no other gods before Me. — You shall not make for yourself an idol.</p> <p>Exodus 20:3,4</p>	<p>You shall not misuse the name of the Lord your God. — Remember the Sabbath day by keeping it holy.</p> <p>Exodus 20:7,8</p>	<p>Honor your father and mother. — You shall not murder. — You shall not commit adultery.</p> <p>Exodus 20:12-14</p>	<p>You shall not steal. — You shall not give false testimony against your neighbor.</p> <p>Exodus 20:15,16</p>	<p>You shall not covet your neighbor's house.</p> <p>Exodus 20:17</p>	<p>"He held fast to the Lord and did not cease to follow Him; He kept the commands the Lord had given Moses."</p> <p>2 Kings 18:6</p>	<p>"All Scripture is God-breathed and is useful for teaching, rebuking, correcting and training in righteousness, so that the man of God may be thoroughly equipped for every good work."</p> <p>2 Timothy 3:16</p>
<p>You shall have no other gods before Me. — You shall not make for yourself an idol.</p> <p>Exodus 20:3,4</p>	<p>You shall not misuse the name of the Lord your God. — Remember the Sabbath day by keeping it holy.</p> <p>Exodus 20:7,8</p>	<p>Honor your father and mother. — You shall not murder. — You shall not commit adultery.</p> <p>Exodus 20:12-14</p>	<p>You shall not steal. — You shall not give false testimony against your neighbor.</p> <p>Exodus 20:15,16</p>	<p>You shall not covet your neighbor's house.</p> <p>Exodus 20:17</p>	<p>"He held fast to the Lord and did not cease to follow Him; He kept the commands the Lord had given Moses."</p> <p>2 Kings 18:6</p>	<p>"All Scripture is God-breathed and is useful for teaching, rebuking, correcting and training in righteousness, so that the man of God may be thoroughly equipped for every good work."</p> <p>2 Timothy 3:16</p>
<p>You shall have no other gods before Me. — You shall not make for yourself an idol.</p> <p>Exodus 20:3,4</p>	<p>You shall not misuse the name of the Lord your God. — Remember the Sabbath day by keeping it holy.</p> <p>Exodus 20:7,8</p>	<p>Honor your father and mother. — You shall not murder. — You shall not commit adultery.</p> <p>Exodus 20:12-14</p>	<p>You shall not steal. — You shall not give false testimony against your neighbor.</p> <p>Exodus 20:15,16</p>	<p>You shall not covet your neighbor's house.</p> <p>Exodus 20:17</p>	<p>"He held fast to the Lord and did not cease to follow Him; He kept the commands the Lord had given Moses."</p> <p>2 Kings 18:6</p>	<p>"All Scripture is God-breathed and is useful for teaching, rebuking, correcting and training in righteousness, so that the man of God may be thoroughly equipped for every good work."</p> <p>2 Timothy 3:16</p>

# SCROLL-A-DAY

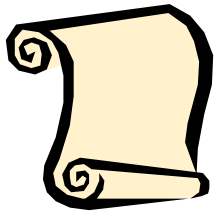

Josiah found true treasure in the wall of the temple.

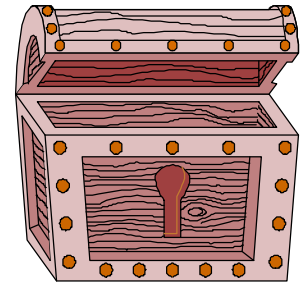

Open one scroll each day this week  
and find some of the treasure God's Word has for you!

MON						WED		
X			TUE			X		
			X					
	THU							
X					FRI			
					X			
		SAT						
		X				SUN		
						X		

# *Renewing Our Covenant*

*“And God spoke all these words:  
‘I am the LORD your God, who brought you out of Egypt, out of the land of slavery.*

*You shall have no other gods before Me.*

*You shall not make for yourself an idol in the form of anything in heaven above or on the earth beneath or in the waters below. You shall not bow down to them or worship them: for I, the LORD your God, am a jealous God, punishing the children for the sins of the fathers to the third and fourth generation of those who hate Me, but showing love to a thousand generations of those who love Me and keep My commandments.*

*You shall not misuse the name of the LORD your God, for the LORD will not hold anyone guiltless who misuses His name.*

*Remember the Sabbath day by keeping it holy. Six days you shall labor and do all your work, but the seventh day is a Sabbath to the LORD your God. On it you shall not do any work, neither you, nor your son or daughter, nor your manservant or maidservant, nor your animals, nor the alien within your gates. For in six days the LORD made the heavens and the earth, the sea, and all that is in them, but He rested on the seventh day. Therefore the LORD blessed the Sabbath day and made it holy.*

*Honor your father and your mother, so that you may live long in the land the LORD your God is giving you.*

*You shall not murder.*

*You shall not commit adultery.*

*You shall not steal.*

*You shall not give false testimony against your neighbor.*

*You shall not covet your neighbor’s house. You shall not covet your neighbor’s wife, or his manservant or maidservant, his ox or donkey, or*

***“The king stood by the pillar and renewed the covenant in the presence of the LORD—to follow the LORD and keep His commands, regulations and decrees with all his heart and all his soul, thus confirming the words of the covenant written in this book. Then all the people pledged themselves to the covenant.”***

***2 Kings 23:3***

# Precious Jewels

## Materials needed:

sequins  
glue  
18-inch piece of yarn  
hole punch  
scissors

## Directions:

1. Cut out the scroll.
2. Punch holes at the top and string the yarn through and tie the ends together in a knot.
3. Glue the sequins at the beginning of each verse.
4. Hang the scroll up as a reminder that God's Word is a priceless treasure. It may also be worn as a necklace.

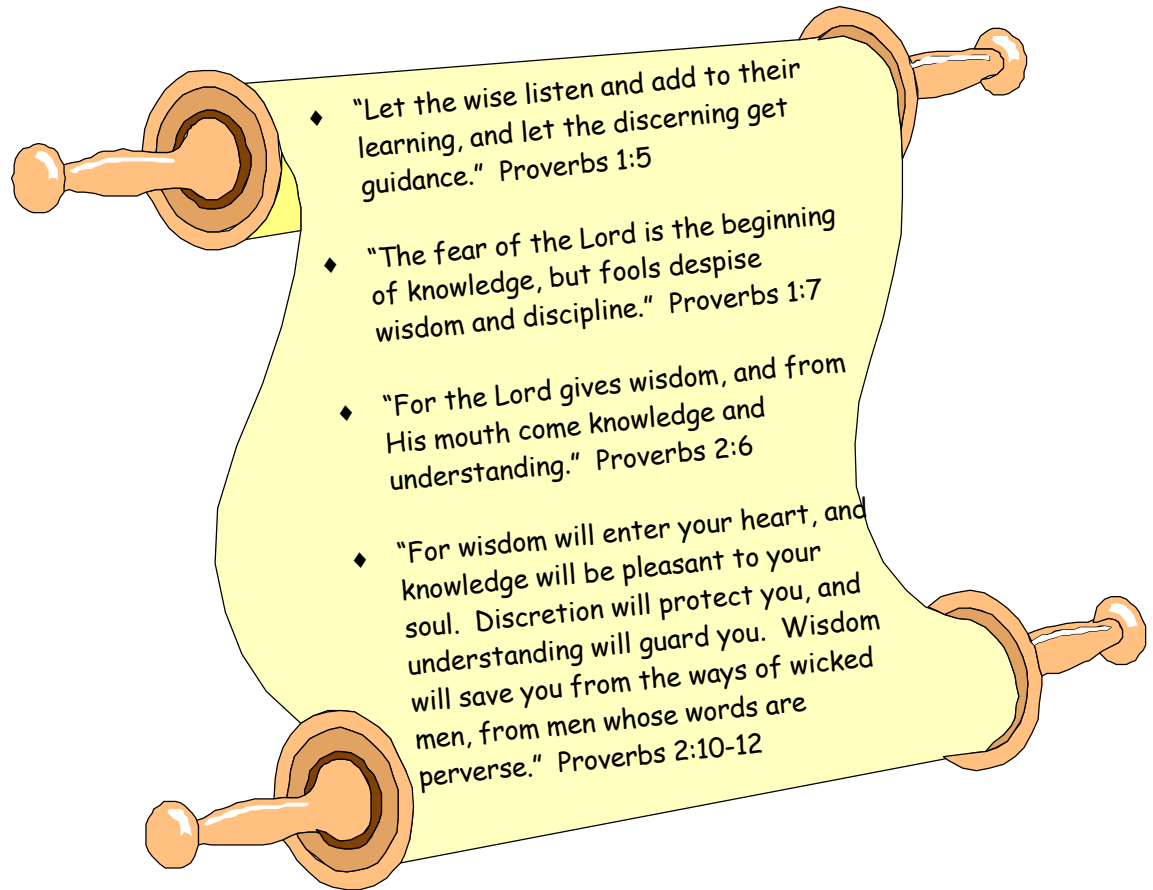



### Surprise in the Rubble

Have a corner of the room filled with a pile of miscellaneous items. This can be chairs, boxes, blankets, bins, cans, etc. Tell your family that someone has left a huge mess from the night before and that before they can have Family Bible Night they will need to clean it up. They may grumble a bit about having to clean up the mess, but hopefully once they begin cleaning and find the candy you have hidden in the rubble, they will want to continue until everything is picked up. Make sure you hide enough candies so that they will continue to find these little treasures as they clean up. Discuss how a very special treasure was discovered in the rubble of the temple.



### Find the Bible Game

Have your family and friends sit on their knees in a circle around another child (Josiah). Review the portions of Scripture where it tells about how the Book of the Law had been lost, when it was found, and when it was read to all of the Israelites. Instruct the child in the center of the circle to cover his eyes while the other children, with their hands behind their backs, pass the Bible around in the circle. While they are doing this, they all say:

Josiah, Josiah,	God's words to us,
The Bible is Lost!	It's hard to measure,
We must find it,	So special to all,
Whatever the cost.	Life's real treasure.

At the conclusion of this rhyme, "Josiah" may open his eyes and try to guess who has the Bible behind his or her back. He may have three guesses to find the Bible. If he makes the correct choice, that person then gets to be "Josiah" in the center. If he chooses incorrectly, he must stay in the center of the circle for another turn.



FAITH BIBLE CHURCH

03/25/2001

# FAMILY FUN SHEET

This is what we learned today:

- Passage ~**  
2 Kings 22-25
- Memory Verse ~**  
"He held fast to the LORD and did not cease to follow Him; he kept the commands the LORD had given Moses."  
2 Kings 18:6

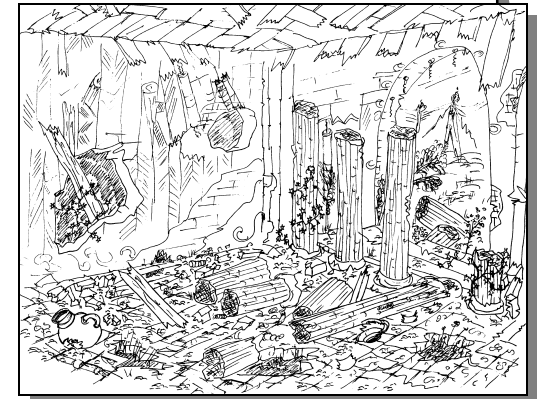

- Application Points ~**

◆ God's Word is a treasure.



### Thy Word

by Amy Grant and Michael W. Smith

Thy Word is a lamp unto my feet  
And a light unto my path.  
Thy Word is a lamp unto my feet  
And a light unto my path.  
When I feel afraid, think I've lost my way,  
Still You're there right beside me.  
And nothing will I fear as long as You are near.  
Please be near me to the end.

## PASSAGE

### Daily Bible Reading:

**Day 1:** Chapter 22

**Day 2:** Chapter 23:1-20

**Day 3:** Chapter 23:21-37

**Day 4:** Chapter 24

**Day 5:** Chapter 25

### Family Bible Night: 2 Kings 22-25

King Amon was killed by his own servants at the young age of 24. He had a son named Josiah who was eight years old at the time and became king in his father's place. Even though his father was wicked, Josiah loved the Lord deeply. At the age of 26, after 18 years of being the king, he desired to rebuild the temple. The temple that Solomon had built had been neglected during the reigns of Manasseh and Amon. King Manasseh even built pagan altars in it and brought in idols. Since they did not love the Lord, they cared little about His temple. But Josiah loved God and wanted the temple restored so that the people might worship Him again.

He took the money that had been collected at the temple and paid workmen to repair the damages done to the temple. They made an incredible discovery while the work was being done to the temple. They found the Book of the Law that Moses had written! One of the scribes then read the Scriptures to Josiah, and after he heard the words of the Lord, he tore his clothes. Now why would he do that after hearing God's Word? To tear one's clothes was a sign of great grief and despair. Josiah realized that the nation of Judah had totally rebelled against God's commands and deserved His punishment for their sins. He then asked the high priest to go and inquire of the Lord what He was going to do to the nation of Judah.

After the priests went before the Lord, God gave Josiah a message. The message was that God's judgment upon the nation would be withheld since Josiah had truly humbled himself before Him. Josiah would not see God's punishment upon Judah during his lifetime, but a later generation would instead.

Josiah then made a covenant with the Lord. He gathered all the people of Judah together and read them the Word of God. They committed themselves to walk in obedience to the commands of Scripture. Josiah demonstrated his willingness to keep his promise by tearing down all the altars to Baal and items used for idolatry. He destroyed anything that had any association with pagan worship, even taking the lives of the idolatrous priests. Josiah completely did away with all the sinful idolatry that had polluted the land. He obeyed the commands of the Lord, and for the first time since the days of the judges, Judah celebrated the Passover exactly as the law had prescribed.

## PERSONAL APPLICATION

### *God's Word Is a Treasure!*

Can you imagine living life without a Bible? This is the way the people of God lived for over 50 years. They did not know what pleased the Lord or what He despised. They were left to their own opinions of what would be best and right and good. Obviously, their own sinful choices left them under the fierce anger of God. He was not happy with His people because they totally disregarded His commandments found in Scripture. In fact, it was their disobedience to the Law that eventually led to their downfall.

When Josiah heard the words of God, his heart was broken and humbled. This is just the way we should respond to the Word of God when we hear it or read it. Not only did Josiah humble his heart, he obeyed it and called the entire nation to obey it as well. It doesn't do any good to know the Bible but fail to obey what it says. Are there some areas of your heart that are in disobedience to the Lord? If so, find out what God's Word says about your disobedience and how you can walk in obedience to Him.

We should be extremely thankful for the Bible, which is a priceless treasure! God has given us His complete and perfect truth. We don't have to look anywhere else to find the answers we need about life and our relationship to God.

## PRAYER

### Pray for FBC Missionaries and Their Families

Phil and Denise Campbell live in the Philippines, where they work on Bible translation. They are not allowed to live with the people for whom they translate the Bible in Indonesia. There is a great conflict between Muslims and Christians there. This conflict makes travel and translation work difficult. Here is how you can pray for the Campbells:

1. Please pray that Bouraq Airlines will keep the flight open between Davao and Manado. This is vital in getting Phil's co-translators back and forth.
2. Continue to pray for the country of Indonesia, that peace will be restored there. Pray that Christians will stand firm in their faith.
3. Pray that all will go well in completing translation on the book